

VAA SERIES

CECC 22220
CECC 22221

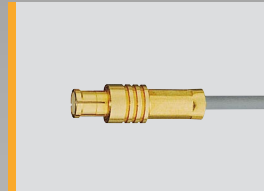
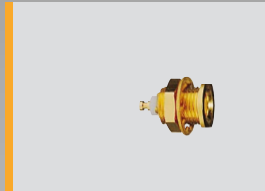

SAA SERIES

DIN 47 297-C
CECC 22230

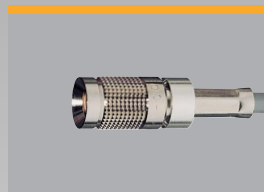
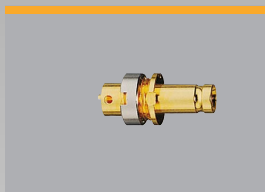

SBA SERIES

DIN 41 626

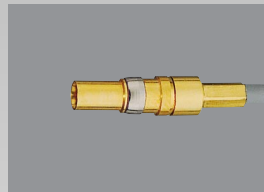
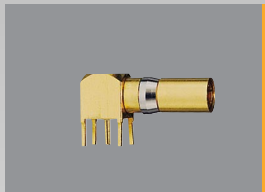

TAA SERIES

DIN 47 295
CECC 22240



COAXIAL CONNECTORS
KOAXIAL STECKVERBINDER



No reproduction or use in any manner of editorial or pictorial content to be made without the express permission of Coelver S.A.

Coelver S.A. reserve the right at all times to modify or improve specifications without any notification.

Ohne ausdrückliche Genehmigung darf kein Text- oder Bildmaterial aus diesem Katalog vervielfältigt werden.

Coelver S.A. behält sich alle Konstruktionsänderungen vor, die der technischen Verbesserung der Produkte dienen.

Index

VAA Series (CECC 22220 and 22221)

General	2
Characteristics	3
Straight plug	4
Straight and elbow plug	5
Fixed, straight and elbow socket	6
Elbow socket	7
Straight socket	7
Straight socket	8
Free and fixed coupler	8
Bridge plug	9
Fixed plug with resistance	9
Straight socket with resistance	9
Adapter	9
Cable assembly (flexible)	10
Cable assembly (semi-rigid)	10
Drilling pattern	11
Tool	11

SAA Series (DIN 47 297-C and CECC 22230)

General	12
Coupling types	13
Characteristics	14
Straight and elbow plug	16
Elbow plug	19
Elbow plug	20
Fixed socket	20
Straight socket	21
Elbow socket	23
Fixed socket	24
Straight socket	24
Straight and elbow socket	25
Elbow socket	26
Straight plug with resistance	26
Straight socket with resistance	27
Coupler	27
Coupler	28
Bridge plug	28
Adapter	29
Accessories	30
Cable assembly	30
Cable assembly (semi-rigid)	32
Drilling pattern	33
Tools	33

SBA Series (DIN 41 626 2nd part)

General	35
Characteristics	36
Straight and elbow plug	37
Elbow plug	38
Fixed socket	38
Elbow socket	38
Straight and elbow socket	39
Cable assembly	40
Drilling pattern	40
Tool	40

TAA Series (DIN 47 295 and CECC 22240)

General	41
Coupling types	42
Characteristics	43
Straight plug	45
Straight and elbow plug	46
Elbow plug	47
Straight socket	47
Straight and elbow socket	48
Straight plug with resistance	49
Straight socket with resistance	50
Coupler	50
Adapter	51
Bridge plug	51
Cable assembly	52
Drilling pattern	54
Tool	54
Cable assembly	55
Recommended cables	55

Inhaltsverzeichnis

Serie VAA (CECC 22220 und 22221)

Allgemeine Angaben	2
Eigenschaften	3
Gerader Stecker	4
Gerader und Winkelstecker	5
Gerade und Winkel-Apparatedose	6
Gerade und Winkel-Apparatedose	7
Kabelkupplung zum Crimpen/zum Lötten	7
Gerade Apparatedose	8
Doppelte Apparatedose	8
Kupplungsstück	9
Gerader Stecker mit Widerstand	9
Apparatedose mit Widerstand	9
Adapter	9
Kabelmontage (flexibel)	10
Kabelmontage (semi-rigid)	10
Bohrungsplan	11
Werkzeug	11

Serie SAA (DIN 47 297-C und CECC 22230)

Allgemeine Angaben	12
Verbindung Modelle	13
Eigenschaften	14
Gerader und Winkelstecker	16
Winkelstecker	19
Winkelstecker	20
Gerade Apparatedose	20
Gerade Apparatedose	21
Winkeldose	23
Winkeldose	24
Gerade Apparatedose	24
Gerade und Winkel-Apparatedose	25
Winkeldose	26
Gerader Stecker mit Widerstand	26
Gerade Apparatedose mit Widerstand	27
Gerade Kupplung	27
Gerade Kupplung	28
Kupplungsstück	28
Adapter	29
Zubehör	30
Kabelmontage	30
Kabelmontage (semi-rigid)	32
Bohrungsplan	33
Werkzeuge	33

Serie SBA (DIN 41 626 Absatz 2)

Allgemeine Angaben	35
Eigenschaften	36
Gerader und Winkelstecker	37
Winkelstecker	38
Gerade Apparatedose	38
Winkeldose	38
Gerade und Winkel-Apparatedose	39
Kabelmontage	40
Bohrungsplan	40
Werkzeug	40

Serie TAA (DIN 47 295 und CECC 22240)

Allgemeine Angaben	41
Verbindung Modelle	42
Eigenschaften	43
Gerader Stecker	45
Gerader und Winkelstecker	46
Winkelstecker	47
Gerade Apparatedose	47
Gerade und Winkel-Apparatedose	48
Gerader Stecker mit Widerstand	49
Gerade Apparatedose mit Widerstand	50
Gerade Kupplung	50
Adapter	51
Kupplungsstück	51
Kabelmontage	52
Bohrungsplan	54
Werkzeug	54
Kabelmontage	55
Empfohlene Kabel	55

Microminiature Coaxial Connectors (50 Ω) CECC 22220 - 22221

Koaxial Microminiatur Steckverbinder (50 Ω) CECC 22220 - 22221

VAA Series

The COELVER VAA is a Series of coaxial (50 Ω) connectors according to specifications CECC 22220-22221 (MCX Series).

It allows high density use in a small area, giving a space saving of 30% to 40%, when compared with SMB connectors. Because of careful precision manufacturing along with tight quality control at each and every production stage and its very small dimensions, the connectors of the VAA Series can be used up to a frequency of 2 GHz.

All these qualities make these connectors particularly suitable on new developments for both civil and military radio applications.

Depending on the model, these connectors are available in gold (Au) nickel (Ni) or tin plated (Sn) versions.

VAA Serie

Die COELVER-Steckverbindung, Serie VAA, 50 Ohm, ist nach der Spezifikation CECC 22220-22221 (MCX-Serie) ausgerichtet.

Durch die extrem kleinen Abmessungen ist eine Packungsdichte auf engstem Raum, mit einem Raumgewinn von 30% bis 40% im Vergleich zur SMB-Serie, möglich. Dank einer sehr sorgfältigen Ausführung und mit einer Qualitätskontrolle in jeder Fertigungsstufe sind die Steckverbinder der Serie VAA für Frequenzen bis zu 2 GHz einsetzbar. Durch diese Eigenschaften werden die Steckverbindungen, besonders für neue Geräte, im Senderfrequenzbereich für zivile oder militärische Anwendungen benutzt.

Gemäß den Modellen sind diese Steckverbindungen in vergoldeten (Au), vernickelten (Ni) oder verzinneten (Sn) Versionen verfügbar.

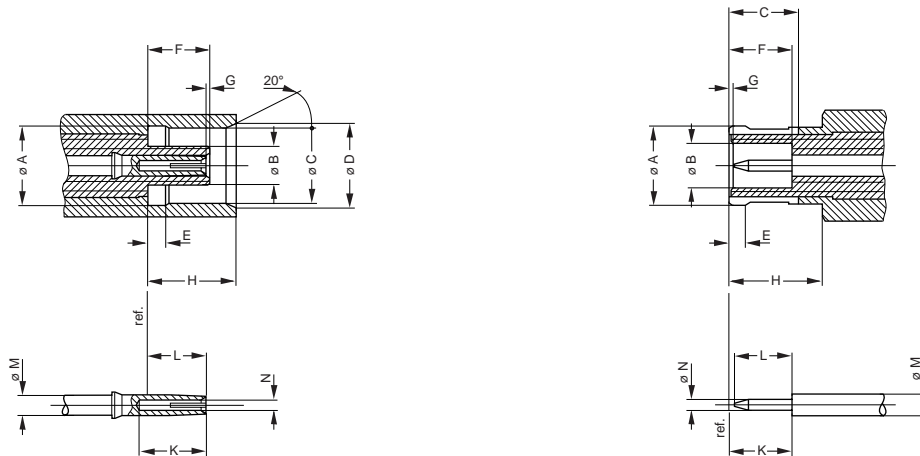

Socket / Apparatedose

LTR	Dimensions / Dimensionen (mm)	
	min.	max.
A	3.60	3.85
B	–	1.98
C	3.42	3.48
D	3.80	–
E	0.75	0.85
F	2.60	2.80
G	–	0.30
H	4.00	4.12
K	2.80	–
L	2.25	2.55
M	–	–
N	1)	–

Dimensions for connectors in general use according to CECC 22220-22221.

1) Appropriate dimension to meet the mating and unmating forces as shown in the 'Mechanical Characteristics' table.

2) Nominal value

Plug / Stecker

LTR	Dimensions / Dimensionen (mm)	
	min.	max.
A	1)	–
B	2.00	–
C	3.70 ²⁾	–
E	–	–
F	2.80	–
G	0.00	0.30
H	4.15	–
I	0.20	0.25
K	2.80	3.20
L	2.75	2.80
M	–	–
N	0.48	0.53

Dimensionen für allgemeine verwendene Steckverbinder gemäss CECC 22220-22221.

1) Dimensionen zur Einhaltung der Angaben der Verriegelungs- und Entriegelungskräfte in der Tabelle der 'Mechanische Eigenschaften'.

2) Nominale Werte

Characteristics / Eigenschaften

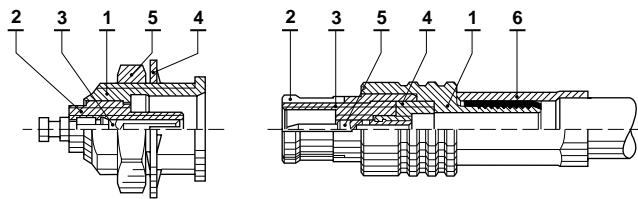

Fixed socket, nut fixing
Apparatedose, Befestigung mit Mutter

Straight plug for crimping
Gerader Stecker zum Crimpen

Voltage standing wave ratio (VSWR) Stehwellenverhältnis

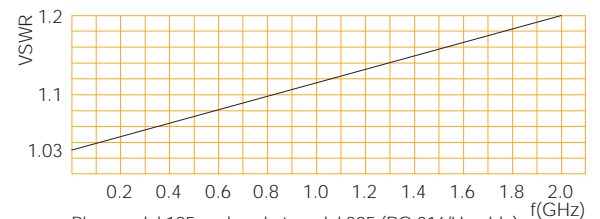

Plug model 185 and socket model 395 (RG.316/U cable)
Stecker Modell 185 und Apparatedose Modell 395 (RG.316/U Kabel). VSWR = 1.03 + 0.08 f(GHz)

Construction

FIXED SOCKET, NUT FIXING

Part	Material (standard)	Treatment
1 Outer shell	Brass (UNS C 38500)	Au=(Cu+Ni) 2.5µm+Au 1µm ¹⁾ Ni=(Cu+Ni) 2.5µm Sn=(Cu+Ni) 6µm+Sn 8µm
2 Insulator	PTFE (ASTM D 1457-83)	
3 Female contact	Cu-Be (QQ-C-530)	(Cu+Ni) 2.5µm+Au 1.5µm
4 Locking washer	Cu-Be (QQ-C-530)	(Cu+Ni) 2.5µm+Au 0.5µm
5 Fixing nut	Brass (UNS C 38500)	(Cu+Ni) 2.5µm+Au 0.5µm

STRAIGHT PLUG FOR CRIMPING

Part	Material (standard)	Treatment
1 Outer shell	Brass (UNS C 38500)	Au=(Cu+Ni) 2.5µm+Au 0.5µm Ni=(Cu+Ni) 2.5µm Sn=(Cu+Ni) 6µm+Sn 8µm
2 Earthing contact	Cu-Be (QQ-C-530)	Au=(Cu+Ni) 2.5µm+Au 1µm Ni=(Cu+Ni) 2.5µm
3 Insulator	PTFE (ASMT D 1457-83)	
4 Insulation sleeve	PTFE (ASTM D 1457-83)	
5 Male contact	Brass (UNS C 34500)	(Cu+Ni) 2.5µm+Au 1µm
6 Crimp ferrule	Copper (UNS C 18700)	(Cu+Ni) 2.5µm+Au 0.5µm

1) The socket housing has a general surface treatment of Au=0.5µm and the contact has a treatment of Au=1µm.

Konstruktion

APPARATEDOSE, BEFESTIGUNG MIT MUTTER

Bestandteile	Material (Norm)	Behandlung
1 Außenkörper	Messing (UNS C 38500)	Au=(Cu+Ni) 2.5µm+Au 1µm ¹⁾ Ni=(Cu+Ni) 2.5µm Sn=(Cu+Ni) 6µm+Sn 8µm
2 Isolationssteil	PTFE (ASTM D 1457-83)	
3 Buchsenkontakt	Cu-Be (QQ-C-530)	(Cu+Ni) 2.5µm+Au 1.5µm
4 Federscheibe	Cu-Be (QQ-C-530)	(Cu+Ni) 2.5µm+Au 0.5µm
5 Befestigungsmutter	Messing (UNS C 38500)	(Cu+Ni) 2.5µm+Au 0.5µm

GERADER STECKER ZUM CRIMPEN

Bestandteile	Material (Norm)	Behandlung
1 Außenkörper	Messing (UNS C 38500)	Au=(Cu+Ni) 2.5µm+Au 0.5µm Ni=(Cu+Ni) 2.5µm Sn=(Cu+Ni) 6µm+Sn 8µm
2 Massekontakt	Cu-Be (QQ-C-530)	Au=(Cu+Ni) 2.5µm+Au 1µm Ni=(Cu+Ni) 2.5µm
3 Isolationssteil	PTFE (ASMT D 1457-83)	
4 Isolationshülse	PTFE (ASTM D 1457-83)	
5 Stiftkontakt	Messing (UNS C 34500)	(Cu+Ni) 2.5µm+Au 1µm
6 Crimphülse	Kupfer (UNS C 18700)	(Cu+Ni) 2.5µm+Au 0.5µm

1) Der Körper der Apparatedose hat eine Oberflächenbehandlung von Au=0.5µm und der Kontaktpunkt hat eine Oberflächenbehandlung von Au=1µm.

Electrical and Climatrical Characteristics

Characteristics	Value
Nominal impedance	50 Ω
Max. operating frequency	2 GHz
VSWR	≤ 1.2
Operating voltage	250 V rms.
Dielectric strength	750 V rms.
Insulation resistance	≥ 10 ⁹ MΩ (at 500 Vdc)
Contact resistance	≤ 3 mΩ
Outer contact resistance	≤ 0.5 mΩ
Rated current	1 A max.
Operating temperature	-55°C +250°C

Mechanical Characteristics

Characteristics	Value
Mating force	(5.5 to 13) N ¹⁾
Unmating force	(7.5 to 20) N ¹⁾
Mechanical endurance	> 700 cycles

Elektrische und Klimatische Eigenschaften

Eigenschaften	Werte
Nominale Impedanz	50 Ω
Max. Betriebsfrequenz	2 GHz
VSWR	≤ 1.2
Betriebsspannung	250 V eff.
Dielektrische Festigkeit	750 V eff.
Isolationswiderstand	≥ 10 ⁹ MΩ (bei 500 Vdc)
Kontaktwiderstand	≤ 3 mΩ
Außenkontaktwiderstand	≤ 0.5 mΩ
Nennstrom	1 A max.
Umgebungstemperatur	-55°C +250°C

Mechanische Eigenschaften

Eigenschaften	Werte
Verriegelungskraft	(5.5 bis 13) N ¹⁾
Entriegelungskraft	(7.5 bis 20) N ¹⁾
Mechanische Lebensdauer	> 700 Zyklen

Cable group Kabelgruppe				Standard Norm			Imp. (Ω)	Type Typ
1	2	3	4	MIL-C-17	96 IEC	CCTU10-01A		
	●			RG.174 A/U	50-2-1	KX3A	50	flexible flexibel
●				RG.178 B/U	50-1-1	KX21A	50	
	●			RG.188 A/U	50-2-3		50	
●				RG.196 A/U	50-1-2		50	
	●			RG.316 /U	50-2-2	KX22A	50	semi-rigid semi-rigid
		●		151-00001			50	
			●	RG.405 /U		KS1	50	

1) The IEC 60512-7 standard test 13a applies only to mating and unmating force measurements.

1) Die IEC 60512-7 Norm test 13a ist nur für Verriegelungskraft und Entriegelungskraft Abmessungen verwendbar.

On request these connectors can be adapted to suit other types of coaxial cables, not shown in the adjacent table, without changing their technical characteristics.

Auf Verlangen ist es möglich, diese Serie von Steckverbinder an andere Typen von Koaxkabeln anzupassen, die nicht in der beigefügten Tabelle vorgestellt sind, ohne daß Veränderungen in ihren technischen Eigenschaften erfolgen.

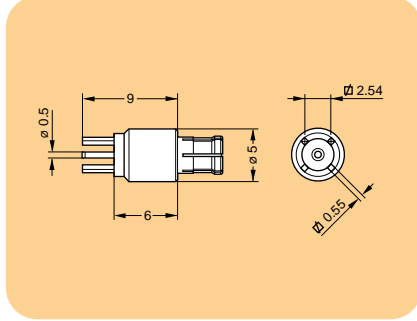
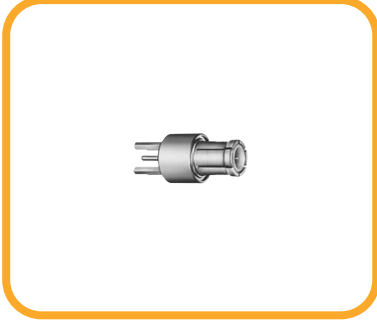
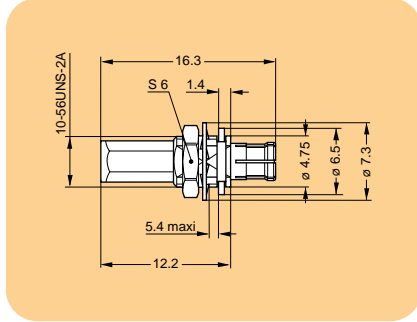
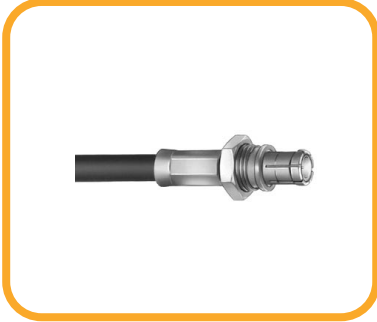
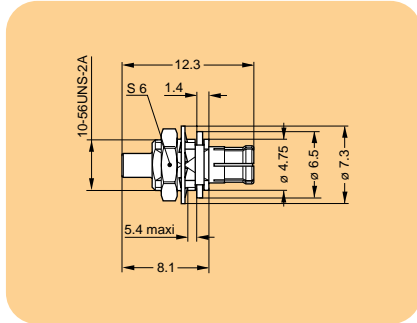
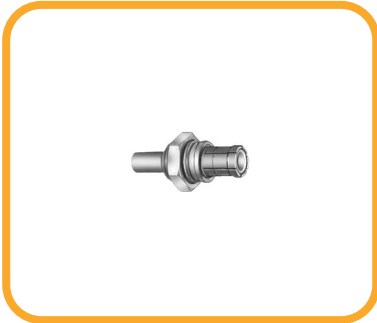
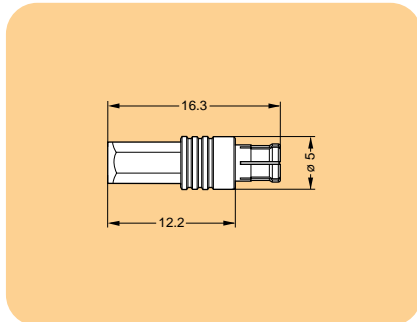
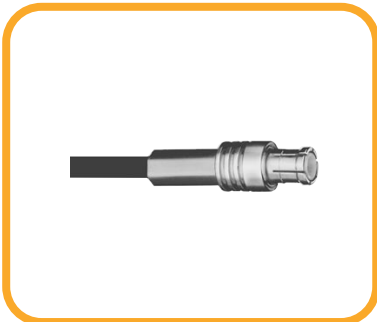
Model / Modell
**Straight plug for soldering onto printed circuit
Gerader Stecker zum Löten auf gedruckter Schaltung**

**Straight plug for crimping, with front fixing
Gerader Stecker zum Crimpen, mit Frontbefestigung**

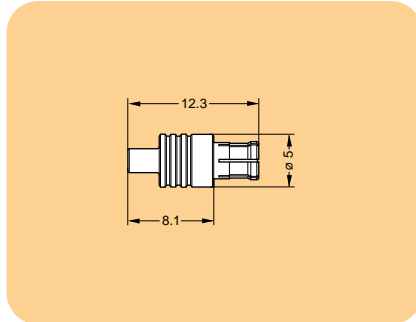
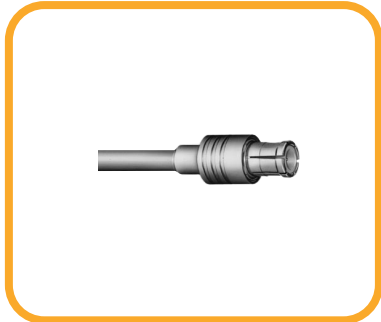
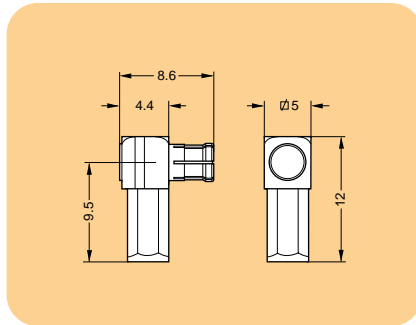
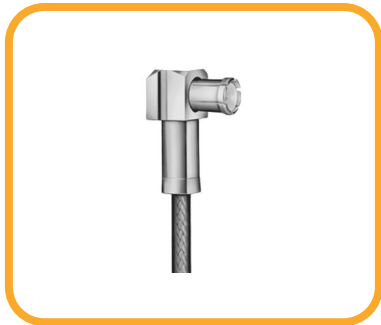
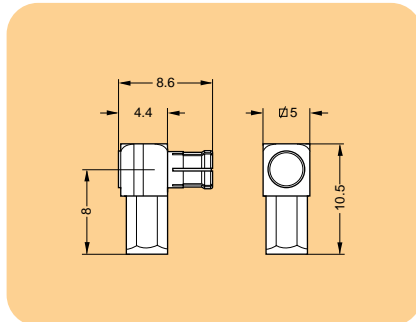
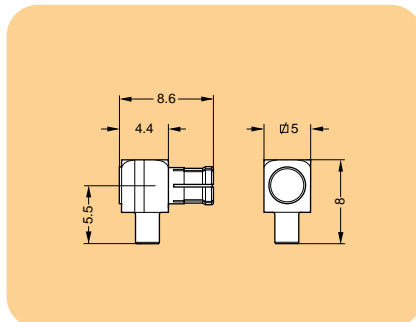
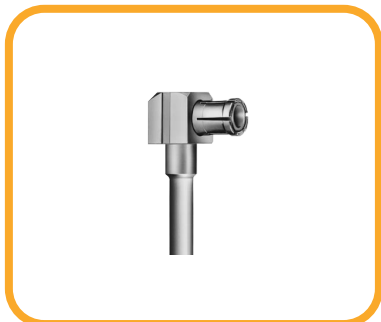
**Straight plug for soldering, with front fixing
Gerader Stecker zum Löten, mit Frontbefestigung**

**Straight plug for crimping
Gerader Stecker zum Crimpen**

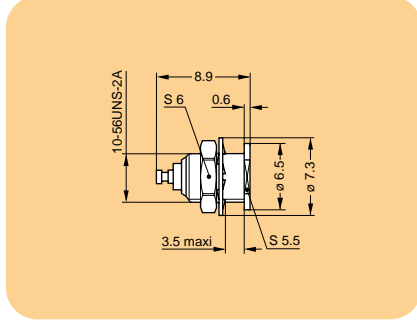
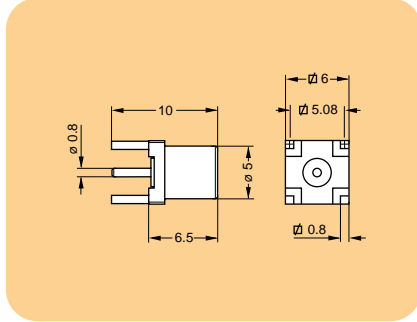
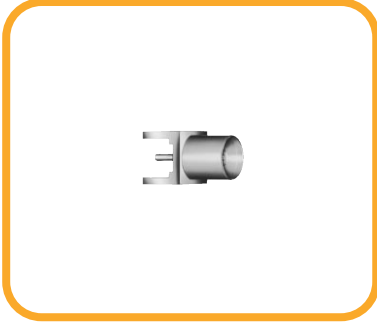
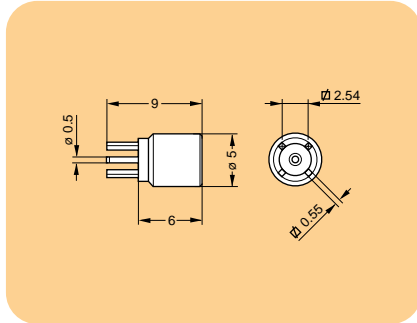
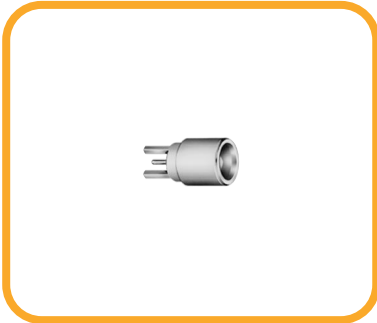
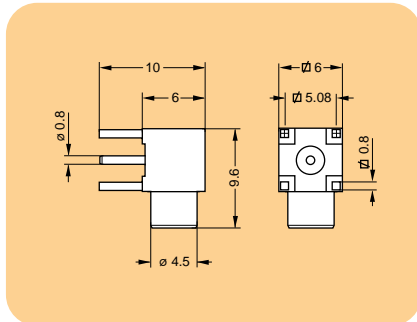
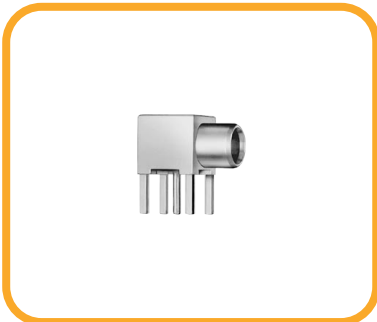
Part number Bestell-Nummer	Cable group Kabelgruppe	Housing finish Körperbehandlung	Cable assembly Kabelmontage	Panel hole or printed circuit Bohrung der Frontpl. oder g. S.
VAA 130.50.10000	-	Au	-	P3
VAA 130.50.20000	-	Ni	-	P3
VAA 130.50.70000	-	Sn	-	P3
VAA.158.50.10121	1	Au	M1	P1
VAA.158.50.10128	2	Au	M1	P1
VAA.158.50.20121	1	Ni	M1	P1
VAA.158.50.20128	2	Ni	M1	P1
VAA.150.50.10121	3	Au	M3	P1
VAA.150.50.10123	4	Au	M3	P1
VAA.150.50.20121	3	Ni	M3	P1
VAA.150.50.20123	4	Ni	M3	P1
VAA.185.50.10121	1	Au	M1	-
VAA.185.50.10128	2	Au	M1	-
VAA.185.50.20121	1	Ni	M1	-
VAA.185.50.20128	2	Ni	M1	-

Model / Modell
**Straight plug for soldering
Gerader Stecker zum Lötén**

**Elbow plug (90°) for crimping
Winkelstecker (90°) zum Crimpen**

**Elbow plug (90°) for crimping
Winkelstecker (90°) zum Crimpen**

**Elbow plug (90°) for soldering
Winkelstecker (90°) zum Lötén**

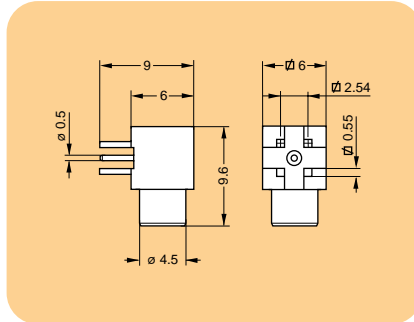
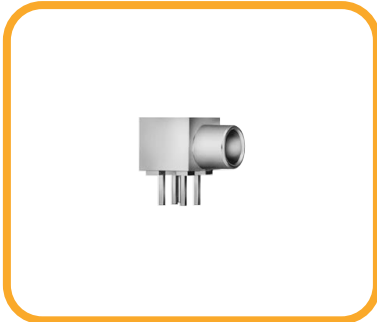
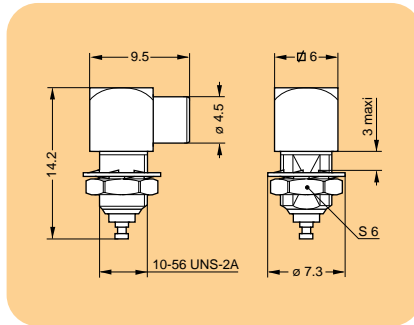
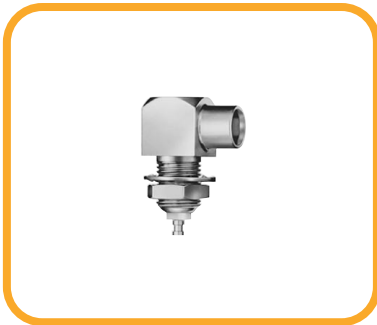
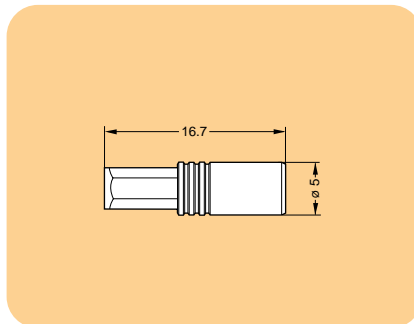
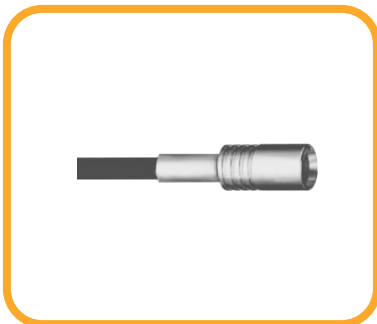
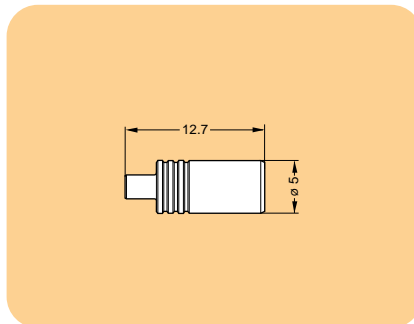
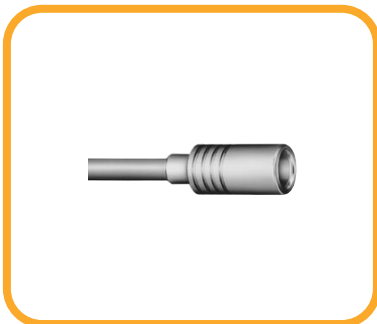
Part number Bestell-Nummer	Cable group Kabelgruppe	Housing finish Körperbehandlung	Cable assembly Kabelmontage	Panel hole or printed circuit Bohrung der Fronipl. oder g. S.
VAA.180.50.10021	3	Au	M3	-
VAA.180.50.10023	4	Au	M3	-
VAA.180.50.20021	3	Ni	M3	-
VAA.180.50.20023	4	Ni	M3	-
VAA.195.50.10021	1	Au	M2	-
VAA.195.50.10028	2	Au	M2	-
VAA.195.50.20021	1	Ni	M2	-
VAA.195.50.20028	2	Ni	M2	-
VAA.194.50.10021	1	Au	M2	-
VAA.194.50.10028	2	Au	M2	-
VAA.194.50.20021	1	Ni	M2	-
VAA.194.50.20028	2	Ni	M2	-
VAA.190.50.10021	3	Au	M4	-
VAA.190.50.10023	4	Au	M4	-
VAA.190.50.20021	3	Ni	M4	-
VAA.190.50.20023	4	Ni	M4	-

Model / Modell
**Fixed socket, nut fixing
Gerade Apparatedose, Befestigung mit Mutter**

**Straight socket for soldering onto printed circuit
Gerade Apparatedose zum Lötén auf gedruckter Schaltung**

**Straight socket for soldering onto printed circuit
Gerade Apparatedose zum Lötén auf gedruckter Schaltung**

**Elbow socket (90°) for soldering onto printed circuit
Winkeldose (90°) zum Lötén auf gedruckter Schaltung**

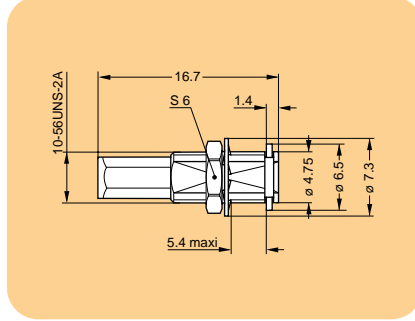
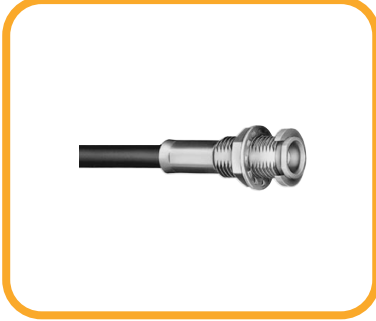
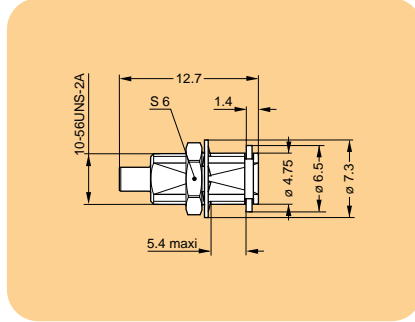
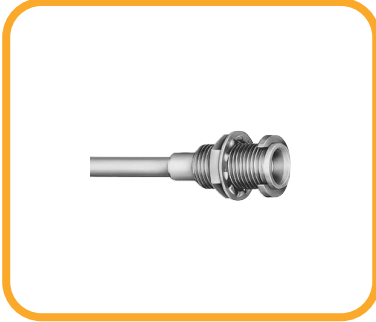
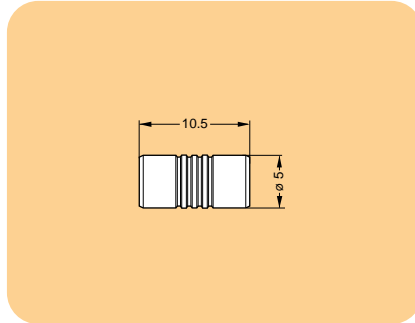
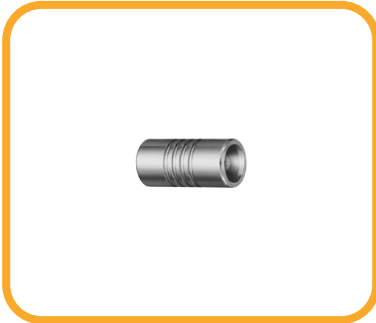
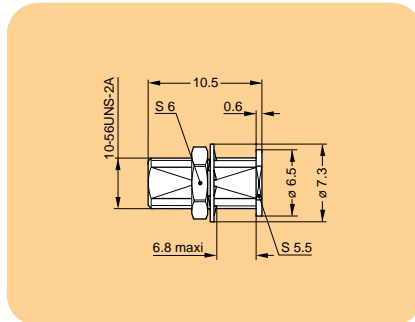
Part number Bestell-Nummer	Cable group Kabelgruppe	Housing finish Körperbehandlung	Cable assembly Kabelmontage	Panel hole or printed circuit Bohrung der Frontpl. oder g. S.
VAA.300.50.10600 VAA.300.50.20600	- -	Au Ni	- -	P1 P1
VAA.360.50.10600 VAA.360.50.20600 VAA.360.50.70600	- - -	Au Ni Sn	- - -	P4 P4 P4
VAA.361.50.10600 VAA.361.50.20600 VAA.361.50.70600	- - -	Au Ni Sn	- - -	P3 P3 P3
VAA.366.50.10600 VAA.366.50.20600 VAA.366.50.70600	- - -	Au Ni Sn	- - -	P4 P4 P4

Model / Modell
**Elbow socket (90°) for soldering onto printed circuit
Winkeldose (90°) zum Lötten auf gedruckter Schaltung**

**Elbow socket (90°), nut fixing
Winkeldose (90°), Befestigung mit Mutter**

**Straight socket for crimping
Kabelkupplung zum Crimpen**

**Straight socket for soldering
Kabelkupplung zum Lötten**

Part number Bestell-Nummer	Cable group Kabelgruppe	Housing finish Körperbehandlung	Cable assembly Kabelmontage	Panel hole or printed circuit Bohrung der Frontpl. oder g. S.
VAA.367.50.10600	-	Au	-	P3
VAA.367.50.20600	-	Ni	-	P3
VAA.367.50.70600	-	Sn	-	P3
VAA.330.50.10600	-	Au	-	P2
VAA.330.50.20600	-	Ni	-	P2
VAA.326.50.10721	1	Au	M1	-
VAA.326.50.10728	2	Au	M1	-
VAA.326.50.20721	1	Ni	M1	-
VAA.326.50.20728	2	Ni	M1	-
VAA.320.50.10621	3	Au	M3	-
VAA.320.50.10623	4	Au	M3	-
VAA.320.50.20621	3	Ni	M3	-
VAA.320.50.20623	4	Ni	M3	-

Model / Modell
**Straight socket for crimping, with front fixing
Gerade Apparatedose zum Crimpen, mit Frontbefestigung**

**Straight socket for soldering, with front fixing
Gerade Apparatedose zum Löten, mit Frontbefestigung**

**Free coupler, female-female
Doppelte Apparatedose, Buchse-Buchse**

**Fixed coupler, nut fixing, female-female
Doppelte Apparatedose, Befestigung mit Mutter, Buchse-Buchse**

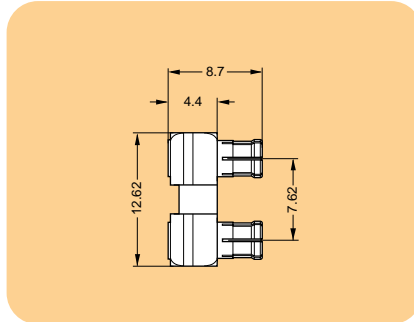
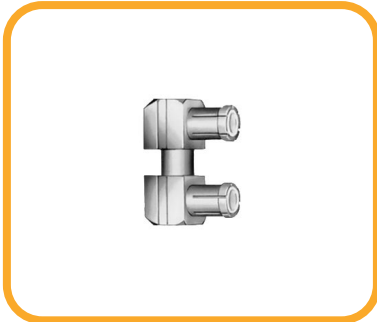
Part number Bestell-Nummer	Cable group Kabelgruppe	Housing finish Körperbehandlung	Cable assembly Kabelmontage	Panel hole or printed circuit Bohrung der Frontpl. oder g. S.
VAA.395.50.10721	1	Au	M1	P1
VAA.395.50.10728	2	Au	M1	P1
VAA.395.50.20721	1	Ni	M1	P1
VAA.395.50.20728	2	Ni	M1	P1
VAA.390.50.10621	3	Au	M3	P1
VAA.390.50.10623	4	Au	M3	P1
VAA.390.50.20621	3	Ni	M3	P1
VAA.390.50.20623	4	Ni	M3	P1
VAA.505.50.10800	-	Au	-	-
VAA.505.50.20800	-	Ni	-	-
VAA.515.50.10800	-	Au	-	P1
VAA.515.50.20800	-	Ni	-	P1

Model / Modell

Bridge-plug, male-male Kupplungsstück, Stift-Stift



Fixed plug with resistance (50 Ω) / 0.4 W Gerader Stecker mit Widerstand (50 Ω) / 0.4 W

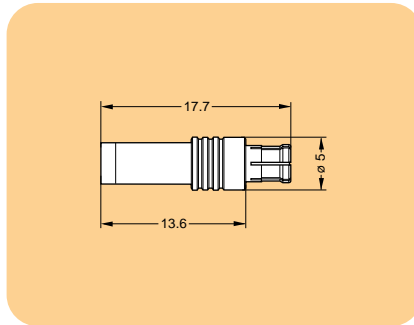
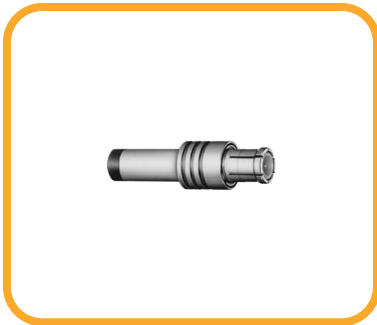

Straight socket with resistance (50 Ω) / 0.4 W Gerade Apparatedose mit Widerstand (50 Ω) / 0.4 W

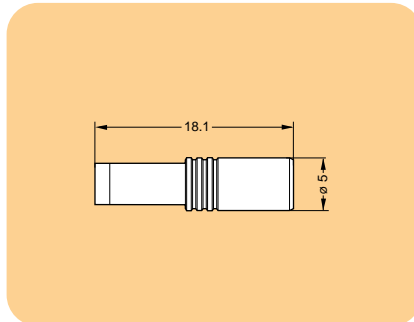
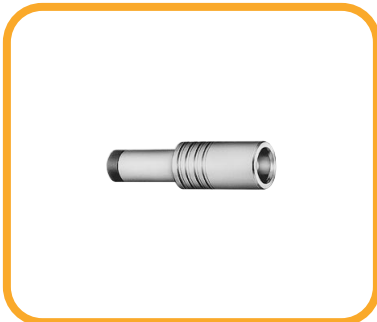

VAA Adapter plug and BNC socket Adapter VAA Stecker und BNC Apparatedose

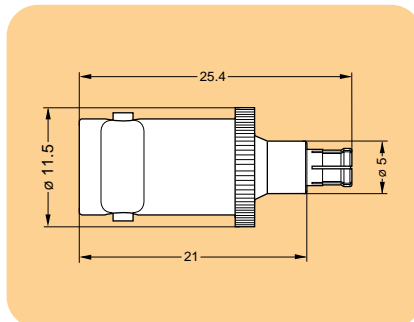
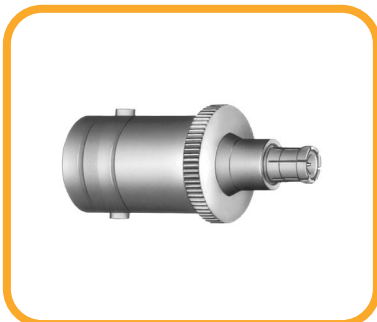

Part number Bestell-Nummer	Cable group Kabelgruppe	Housing finish Körperbehandlung	Cable assembly Kabelmontage	Panel hole or printed circuit Bohrung der Frontpl. oder g. S.
VAA.560.50.10076 VAA.560.50.20076	- -	Au Ni	- -	- -
	Resistance (Ω) Widerstand (Ω)			
VAA.171.50.10001 VAA.171.50.20001	50 50	Au Ni	- -	- -
VAA.371.50.10601 VAA.371.50.20601	50 50	Au Ni	- -	- -
	Cable group Kabelgruppe			
VAA.755.50.20500	-	Ni	-	-

M: Cable Assembly / Kabelmontage

Connectors for crimping (flexible cable)

Steckverbinder zum Crimpen (flexibles Kabel)

- 1** Strip cable to dimensions shown in adjacent table. Slide crimp ferrule ① onto cable.

Kabel gemäß den Angaben der nachstehenden Tabelle abisolieren. Kabel in die Crimphülse ① einführen.

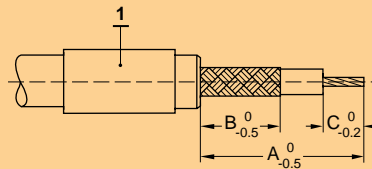

M	Dimensions Dimensionen (mm)		
	A	B	C
M1	10	4.7	2.8
M2	8	4.7	1.7

- 2** Fit cable conductor into contact ②. Crimp using the corresponding crimping tool. Expand screen.

Kabelleiter in den Kontakt ② einführen. Mit der entsprechenden Zange crimpen. Die Abschirmung ausweiten.

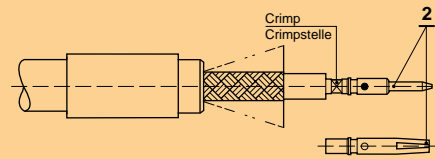

- 3** Slide cable into connector housing until dielectric butts up against insulator. Gently pull cable to check retention of contact in the insulator. Slide crimp ferrule ① over screen until it reaches connector housing ③. Crimp with corresponding crimping tool.

Das Kabel in den Kontaktkörper bis zum Anschlag des Dielektrikums gegen das Isolationsteil einführen. Das Kabel leicht zurückziehen, um den Sitz des Kontakts im Isolierkörper zu prüfen. Die Crimphülse ① über den Kabelschirm bis zum Anschlag gegen den Steckerkörper ③ schieben. Mit der entsprechenden Zange ⑤ crimpen.

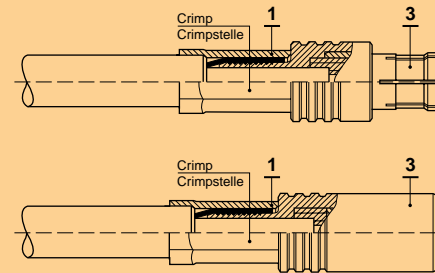

- 4** After operation 1, expand screen, then introduce cable into connector. Make sure conductor is correctly located in the contact slot; tin solder through hole in shell. Slide crimp ferrule ① over screen until it reaches connector housing ③. Crimp with corresponding crimping tool. Pass insulating sleeve ④ through hole in shell and then press in blanking cap ⑤.

Nach der Ausführung der Anleitung 1 die Abschirmung ausweiten, das Kabel in den Steckerkörper einführen. Kontrollieren, ob der Leiter richtig in die Kontaktöffnung eingeführt ist. Durch die Öffnung zinnlöten. Die Crimphülse ① über den Kabelschirm bis zum Anschlag gegen den Steckerkörper ③ schieben. Mit der entsprechenden Zange crimpen. Die Isolationshülse ④ einführen und das Loch mit der Abdeckkappe schließen ⑤.

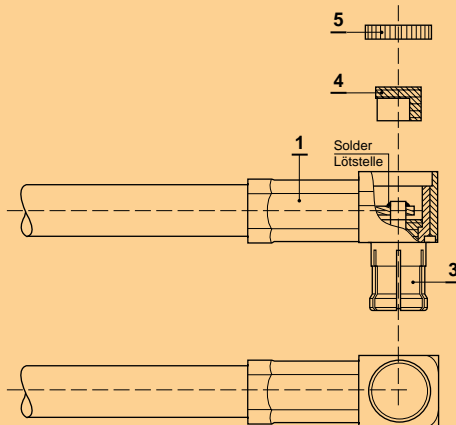

Connectors for soldering (semi-rigid cable)

Steckverbinder zum Löten (semi-rigid Kabel)

- 1** Strip cable to dimensions shown in adjacent table.

Kabel gemäß den Angaben der nachstehenden Tabelle abisolieren.

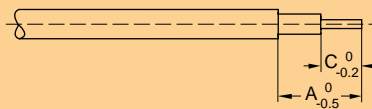

M	Dim. (mm)	
	A	C
M3	5.2	2.8
M4	3.8	1.7

- 2** Fit conductor into contact ① and tin solder.

Kabelleiter in den Kontakt ① einführen und zinnlöten.

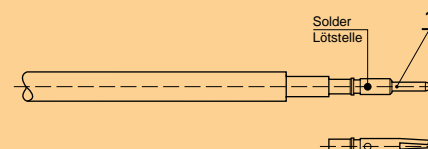

- 3** Slide cable gently into housing ② until dielectric butts up against insulator. Gently pull cable to check retention of contact within the insulator. Solder outer screen into housing through its slot.

Das Kabel in den Kontaktkörper ② bis zum Anschlag des Dielektrikums gegen das Isolationsteil einführen. Das Kabel leicht zurückziehen, um den Sitz des Kontakts im Isolierkörper zu prüfen. Den Außenschirm mit dem Stecker an der Lötöffnung löten.

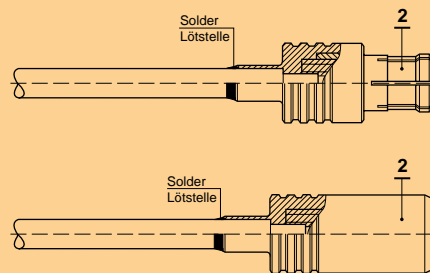

- 4** After operation 1, slide cable into housing. Make sure conductor ① is correctly located in contact slot. Tin solder through the hole in housing. Solder the outer screen of cable into housing through its slot, fit insulating sleeve ③ through hole and then press in blanking cap ④.

Nach der Ausführung der Anleitung 1 das Kabel in den Steckerkörper ① einführen. Kontrollieren, ob der Leiter richtig in die Kontaktöffnung eingeführt ist. Durch die Öffnung löten. Die Außenschirmung des Kabels zwischen der Öffnung mit dem Stecker löten, die Isolationshülse ③ einführen und das Loch des Steckers mit der Abdeckkappe schließen ④.

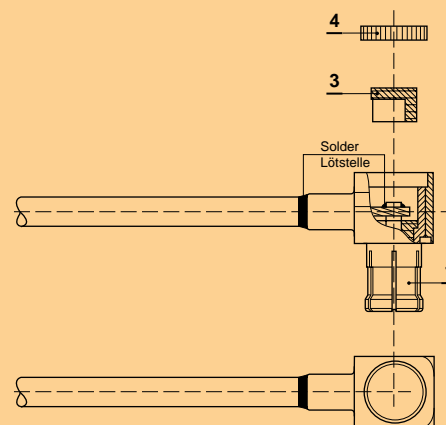

P: Drilling pattern / Bohrungsplan

Panel holes Bohrung der Frontplatte

P	Dimensions Dimensionen (mm)	
	A	B
P1	7.5	7.5
P2	-	7.5

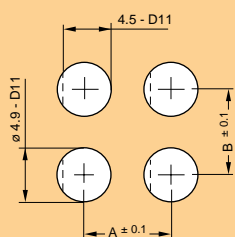

Printed circuit holes Bohrung der gedruckten Schaltung

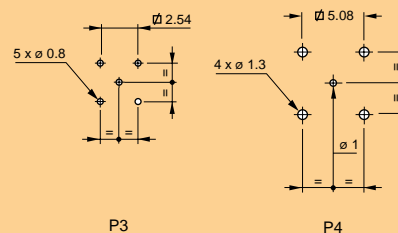

Tool / Werkzeug

Crimping tool Crimpzange

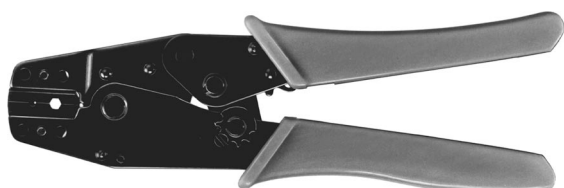

Part Number Bestell-Nummer	Cable group Kabelgruppe	Dimensions Dimensionen (mm)	
		A	B
VAA.950.10380	1-2	0.7	3.28

Coaxial Connectors (50 Ω and 75 Ω) DIN 47 297-C and CECC 22230 Koaxiale Steckverbinder (50 Ω und 75 Ω) DIN 47 297-C und CECC 22230

SAA Series

This 1.0/2.3 coaxial connector series, according to the DIN 47 297-C and CECC 22230 standards, has been conceived for use on the compact structures used in modern transmission techniques, and for high performance/high reliability applications. Its reduced dimensions and high electrical qualities are made possible by the quality of the materials used during manufacturing. Teflon PTFE is used for insulators, Cu-Be for all metal parts requiring a high degree of flexibility, and plating such as gold, silver, nickel or tin.

The COELVER company has developed a wide range of 50 Ω and 75 Ω models. This 1.0/2.3 connector series provides 4 types of couplings according to their application: A form screw type, B form spring type, C form free type and F-form Push-Pull self-latching type offering absolute security against vibration and accidental pull on the cable.

SAA Serie

Die Koaxial-Steckverbindung, Serie 1.0/2.3 entspricht der Norm DIN 47 297-C und CECC 22230. Sie wurde für den Einsatzfall in der Übertragungstechnik bei kompakter Bauweise mit hoher Qualität konstruiert und gefertigt. Die Charakteristik sind ihre reduzierten Abmessungen. Die hohen elektrischen Eigenschaften werden durch die Auswahl der qualitativ hohen Materialien garantiert. Folgende Werkstoffe kommen zum Einsatz: Teflon (PTFE) für alle Isolationsmaterialien und Cu-Be für alle Metallteile mit einem hohen Elastizitätsgrad. Galvanische Schichtdicken sind: Vergolden, Versilbern, Vernickeln und Verzinnen.

Die Firma COELVER fertigt eine breite Modellpalette für Kabel mit 50 Ohm und 75 Ohm. In der Serie 1.0/2.3 sind vier Verriegelungsarten vorgesehen: A Version mit Schraubverriegelung, B Version mit Federverriegelung, C Version mit loser Steckverriegelung und F Version mit dem Push-Pull Selbstverriegelungssystem. Mit dem Push-Pull System ist eine absolute Sicherheit gegen Vibration, sowie durch zufälliges Ziehen auf das Kabel garantiert.

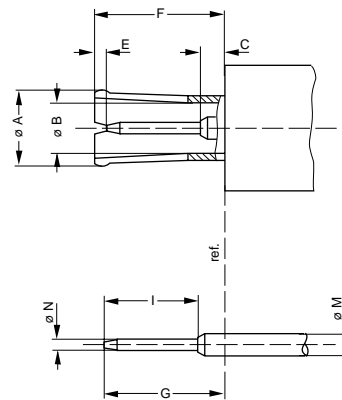
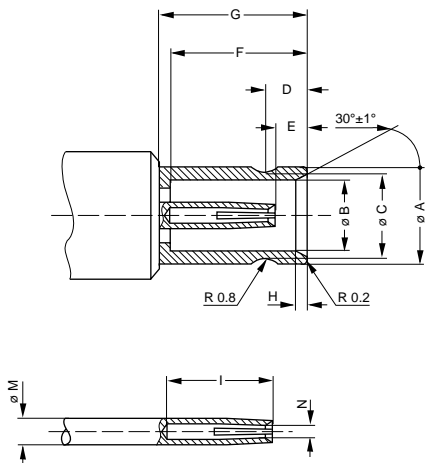

Socket / Apparatedose

LTR	Dimensions/Dimensionen (mm)	
	min.	max.
A	4.03	4.15
B	3.00	3.06
C	3.53	3.60
D	1.80	1.90
E	1.15	1.75
F	5.80	5.90
G	6.40	6.50
H	0.50	0.60
I	4.45	4.55
M	0.97	1.00
N	1)	-

Dimensions for connectors in general use according to CECC 22230.

1) Appropriate dimension to meet the mating and unmating forces as shown in the 'Mechanical Characteristics' table.

Plug / Stecker

LTR	Dimensions/Dimensionen (mm)	
	min.	max.
A	1)	-
B	2.30	2.35
C	-	1.15
D	0.15	0.25
E	0.10	0.50
F	5.40	5.70
G	5.30	5.50
I	4.20	4.30
M	0.97	1.00
N	0.49	0.52

Dimensionen für allgemeine verwendene Steckverbinder gemäss CECC 22230.

1) Dimensionen zur Einhaltung der Angaben der Verriegelungs- und Entriegelungskräfte in der Tabelle der 'Mechanische Eigenschaften'.

Coupling types / Verbindung Modelle

A Form A Version

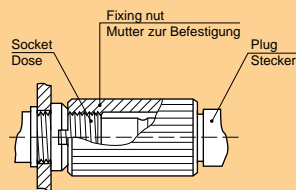

With this type of coupling the plug is easily screwed to the socket by means of the plug's threaded nut.

Mit dieser Verbindung kann der Stecker mit Hilfe von einer auf dem Stecker befestigten Mutter ohne Spannung auf die Dose geschraubt werden.

B Form B Version

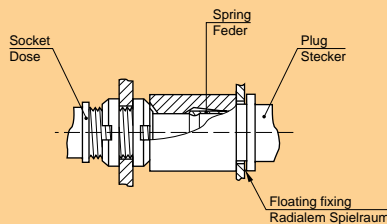

This type of coupling between a plug and a socket is made possible by a sleeve fitted with a spring in the plug, which enables the fixing of the two connectors.

Die Verbindung zwischen Stecker und Dose wird durch eine Hülse ermöglicht, welche über eine Feder ausgerüstet wurde. Hierdurch wird die Verbindung zwischen Buchse und Stecker hergestellt.

C Form C Version

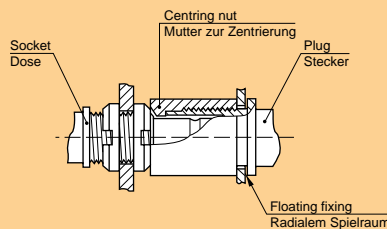

This type of free coupling between a plug and a socket is made possible by a conical guide screwed onto the plug which provides a perfect centering between the two connectors.

Bei der frei steckbaren Type wird die Zentrierung zwischen den beiden Steckern durch den Eingangskonus ermöglicht, mit welchem der Stecker ausgerüstet ist.

F form self-latching connection F Version Push-Pull selbstverriegelnde Verbindung

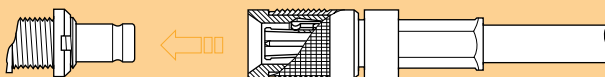

This new type of patented self-latching coupling provides a simple and quick mating between a plug and a socket. It is guaranteed against vibration and accidental pull on the cable.

Die neu patentierte Verriegelung erlaubt eine einfache und schnelle Kupplung zwischen Stecker und Dose und ist gegen alle Vibrationen und zufällige Zugkräfte auf das Kabel gesichert.

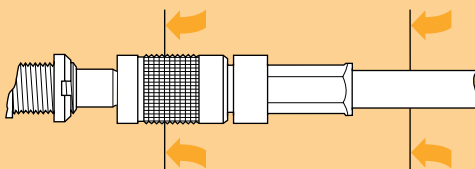

1 A plug and a socket are mated by a simple axial push on the outer shell of the plug or the cable.

Die Verriegelung zwischen Stecker und Dose wird durch einen einfachen axialen Schub über den Außenkörper des Steckers, oder des Kabels erreicht.

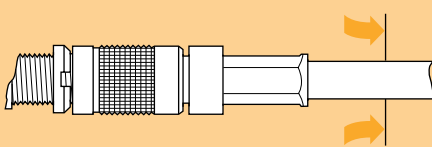

2 A pull on the cable or any part of the plug, other than the external release sleeve, will not release the latch.

Die Verbindung läßt sich nur durch Ziehen am Außenkörper lösen. Durch Ziehen am Kabel oder einem anderen Teil des Steckers ist eine Entriegelung nicht möglich.

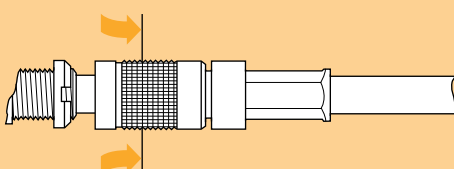

3 To unlatch a plug from a socket, an axial pull must be exerted on the external release sleeve of the plug.

Um den Stecker von der Dose zu entriegeln, muß ein axialer Zug auf den Außenkörper des Steckers ausgeübt werden.

Characteristics / Eigenschaften

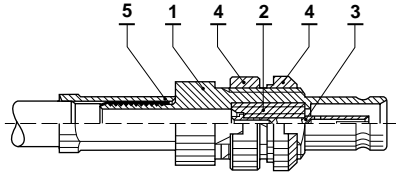

Straight socket for crimping
Gerade Apparatedose zum Crimpen

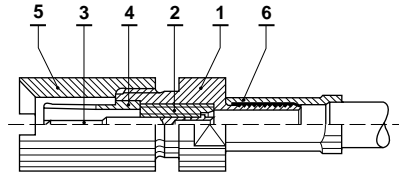

Straight plugs for crimping
Gerade Stecker zum Crimpen

Examples of Construction

STRAIGHT SOCKET FOR CRIMPING

Part	Material (standard)	Treatment
1 Housing	Brass (UNS C 38500)	(Cu+Ni) 2.5µm+Au 1µm ¹⁾
2 Insulator	PTFE (ASTM D 1457-83)	
3 Female contact	Cu-Be (QQ-C-530)	(Cu+Ni) 2.5µm+Au 1.5µm
4 Fixing nut	Brass (UNS C 38500)	(Cu+Ni) 2.5µm
5 Crimp ferrule	Copper (UNS C 18700)	(Cu+Ni) 2.5µm

STRAIGHT PLUG FOR CRIMPING

Part	Material (standard)	Treatment
1 Housing	Brass (UNS C 38500)	(Cu+Ni) 2.5µm+Ni 5µm
2 Insulator	PTFE (ASTM D 1457-83)	
3 Male contact:		
solder	Brass (UNS C 38500)	(Cu+Ni) 2.5µm+Au 1µm
crimp	Brass (UNS C 34500)	(Cu+Ni) 2.5µm+Au 1µm
4 Earthing contact	Cu-Be (QQ-C-530)	(Cu+Ni) 2.5µm+Au 1µm
5 Fixing nut	Brass (UNS C 38500)	(Cu+Ni) 2.5µm
6 Crimp ferrule	Copper (UNS C 18700)	(Cu+Ni) 2.5µm
7 Push-Pull self-latching coupling		

1) The socket housing has a general surface treatment of Au=0.5µm and the contact has a treatment of Au=1µm.

Konstruktionsbeispiele

GERADE APPARATEDOSE ZUM CRIMPEN

Bestandteile	Material (Norm)	Behandlung
1 Außenkörper	Messing (UNS C 38500)	(Cu+Ni) 2.5µm+Au 1µm ¹⁾
2 Isolationsteil	PTFE (ASTM D 1457-83)	
3 Buchsenkontakt	Cu-Be (QQ-C-530)	(Cu+Ni) 2.5µm+Au 1.5µm
4 Befestigungsmutter	Messing (UNS C 38500)	(Cu+Ni) 2.5µm
5 Crimpöhülse	Kupfer (UNS C 18700)	(Cu+Ni) 2.5µm

GERADER STECKER ZUM CRIMPEN

Bestandteile	Material (Norm)	Behandlung
1 Außenkörper	Messing (UNS C 38500)	(Cu+Ni) 2.5µm+Ni 5µm
2 Isolationsteil	PTFE (ASTM D 1457-83)	
3 Stiftkontakt:		
zum Löten	Messing (UNS C 38500)	(Cu+Ni) 2.5µm+Au 1µm
zum Crimpen	Messing (UNS C 34500)	(Cu+Ni) 2.5µm+Au 1µm
4 Massekontakt	Cu-Be (QQ-C-530)	(Cu+Ni) 2.5µm+Au 1µm
5 Befestigungsmutter	Messing (UNS C 38500)	(Cu+Ni) 2.5µm
6 Crimpöhülse	Kupfer (UNS C 18700)	(Cu+Ni) 2.5µm
7 Push-Pull selbstverriegelnde Verbindung		

1) Der Körper der Apparatedose hat eine Oberflächenbehandlung von Au=0.5µm und der Kontaktpunkt hat eine Oberflächenbehandlung von Au=1µm.

Examples of coupling arrangement

Kupplungsbeispiele

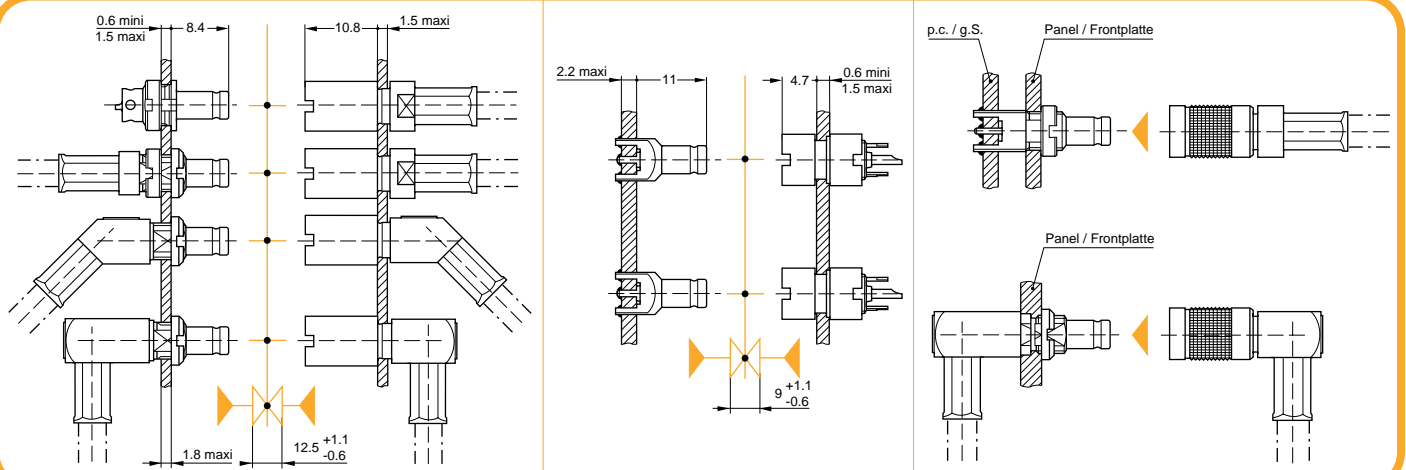

Characteristics / Eigenschaften

Voltage standing wave ratio (VSWR) Stehwellenverhältnis

50 Ω conditions:
Straight plug, model 155 and straight
socket model 325, cable RG.316/U (50 Ω)
VSWR = 1.06 + 0.029 f(GHz)

Bedingungen mit 50 Ω:
Gerader Stecker, Modell 155 und gerade
Dose, Modell 325, RG.316/U Kabel (50 Ω)
VSWR = 1.06 + 0.029 f(GHz)

75 Ω conditions:
Straight plug, model 189 and straight
socket model 324, cable ST.212 (75 Ω)
VSWR = 1.11 + 0.054 f(GHz)

Bedingungen mit 75 Ω:
Gerader Stecker, Modell 189 und gerade
Dose, Modell 324, ST.212 Kabel (75 Ω)
VSWR = 1.11 + 0.054 f(GHz)

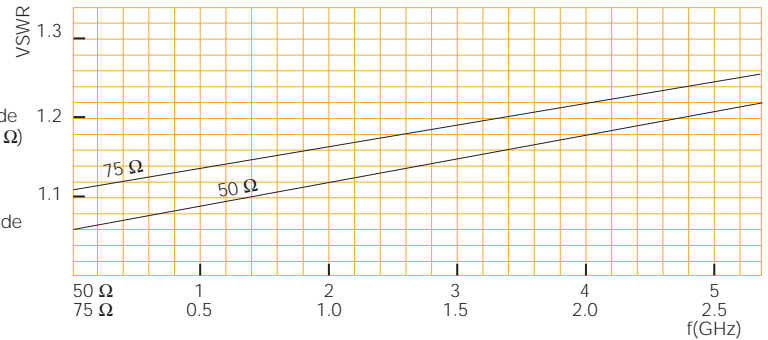

Electrical and Climatrical Characteristics

Characteristics	Value
Nominal impedance	50 Ω 75 Ω
Max. operating frequency	4.8 GHz 1.65 GHz
VSWR	≤ 1.2
Testing voltage	750 V rms. (50 Hz)
Operating voltage	250 V rms. (50 Hz)
Insulation resistance	≥ 10 ⁶ MΩ (at 500 Vdc)
Contact resistance	≤ 3.5 mΩ
Outer contact resistance	≤ 1.5 mΩ
Rated current	6 A
Operating temperature	-55°C +250°C

Elektrische und Klimatische Eigenschaften

Eigenschaften	Werte
Nominale Impedanz	50 Ω 75 Ω
Max. Betriebsfrequenz	4.8 GHz 1.65 GHz
VSWR	≤ 1.2
Prüfspannung	750 V eff. (50 Hz)
Betriebsspannung	250 V eff. (50 Hz)
Isolationswiderstand	≥ 10 ⁶ MΩ (bei 500 Vdc)
Kontaktwiderstand	≤ 3.5 mΩ
Außenkontaktwiderstand	≤ 1.5 mΩ
Nennstrom	6 A
Umgebungstemperatur	-55°C +250°C

Mechanical Characteristics

Characteristics	Value
(C Form)	
Mating force	≤ 6 N ¹⁾
Unmating force	≤ 5 N ¹⁾
Mechanical endurance	> 500 cycles
(Push-Pull self-latching coupling)	
Mating force	≤ 10 N ¹⁾
Unmating force	≤ 8 N ¹⁾
Latch retention force	≥ 450 N
Mechanical endurance	> 500 cycles

¹⁾ The IEC 60512-7 standard test 13a applies only to mating and unmating force measurements.

Mechanische Eigenschaften

Eigenschaften	Werte
(C Version)	
Verriegelungskraft	≤ 6 N ¹⁾
Entriegelungskraft	≤ 5 N ¹⁾
Mechanische Lebensdauer	> 500 Zyklen
(Push-Pull selbstverriegelnde Verbindung)	
Verriegelungskraft	≤ 10 N ¹⁾
Entriegelungskraft	≤ 8 N ¹⁾
Zurückbehaltungskraft	≥ 450 N
Mechanische Lebensdauer	> 500 Zyklen

¹⁾ Die IEC 60512-7 Norm test 13a ist nur für Verriegelungskraft und Entriegelungskraft Abmessungen verwendbar.

Cable group Kabelgruppe		Standard Norm				Imp. (Ω)	Type Typ
0	1 2 3 4 5 6 7 8 9 10 11 12 13	MIL-C-17	96 IEC	CCTU10-01A	Other/Andere		
●		RG.179 B/U	75-2-1			75	flexible flexibel
●		RG.187 A/U	75-2-2			75	
	●	RG.188 A/U	50-2-3			50	
	●	RG.316 /U	50-2-2	KX22A		50	
●					L 910/39	75	
●					1AC004060001	75	
					2YCY(0.4/2.5)	Siemens 75	
					2.5C-2V (JIS C 3501)	75	
					2YCCY (0.4/2.5)	Siemens 75	
					5YC(ms)C6Y45/1.9-75vsws	Gore 75	
					Alcatel thin coax	Alcatel 75	
					8218	Belden 75	
					H.130	Pope 75	
					H.134	Pope 75	
					ST.121 (0.5/2.9)	FMC 75	
					ST.212 (0.4/2.0) R	FMC 75	
					ST.214 (0.81/3.7) R	FMC 75	
		RG.405/U		KS1		50	semi-rigid
					EZ.86-75	75	semi-rigid

On request these connectors can be adapted to suit other types of coaxial cables, not shown in the adjacent table, without changing their technical characteristic.

Auf Verlangen ist es möglich, diese Serie an andere Typen von Koaxkabeln anzupassen, die nicht in der beigefügten Tabelle vorgestellt sind, ohne daß Veränderungen in ihren technischen Eigenschaften erfolgen.

Part number example

SAA.189.50.60135

SAA: DIN 1.0/2.3 Series
189: Model: straight plug for crimping, push-pull coupling
50: Impedance 50 = 50 Ω 75 = 75 Ω
6: Housing finish: 1 = gold 2 = nickel 6 = silver
0: Insulator material: teflon PTFE
1: Type of contact:
0 = male solder contact 1 = male crimp contact
6 = female solder contact 7 = female crimp contact
35: Diameter of cable entry : 35 = 3.5 mm

Beispiel für Bestell-Nummer

SAA.189.50.60135

SAA: DIN 1.0/2.3 Serie
189: Modell: gerader Stecker zum Crimpen, push-pull Selbstverriegelung
50: Impedanz 50 = 50 Ω 75 = 75 Ω
6: Körperbehandlung: 1 = vergoldet 2 = vernickelt 6 = versilbert
0: Isolationsmaterial: teflon PTFE
1: Kontakttyp:
0 = Stiftkontakt zum Lötten 1 = Stiftkontakt zum Crimpen
6 = Buchsenkontakt zum Lötten 7 = Buchsenkontakt zum Crimpen
35: Durchmesser für die Kabeleinführung: 35 = 3.5 mm

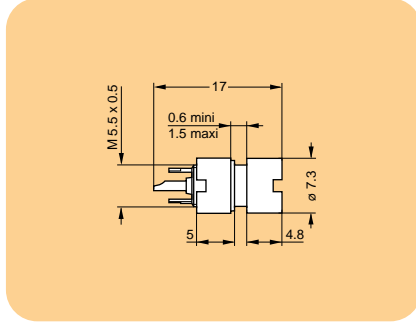
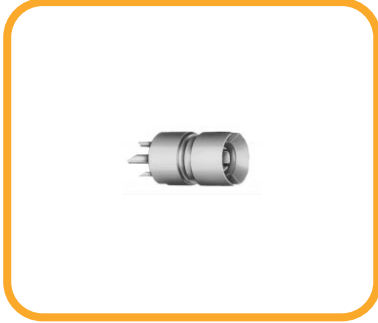
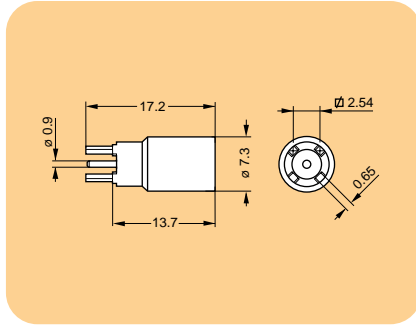
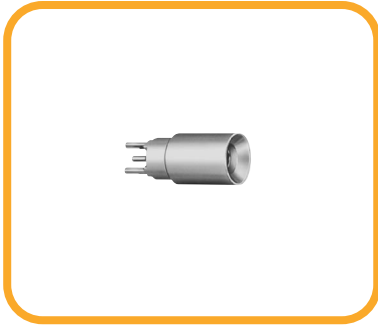
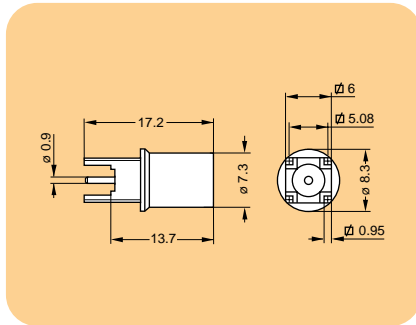
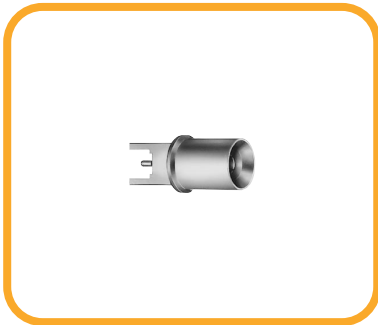
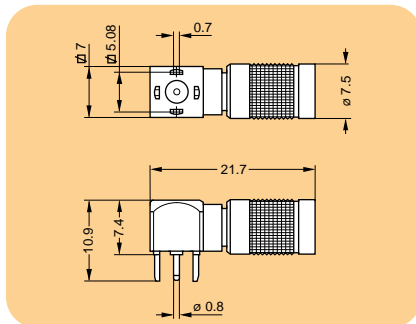
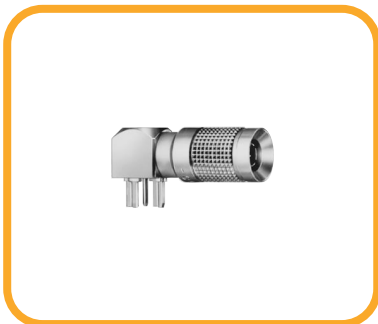
Model / Modell
**Straight plug, nut fixing
Gerader Stecker, Befestigung mit Mutter**

**Straight plug for soldering onto printed circuit
Gerader Stecker zum Lötén auf gedruckter Schaltung**

**Straight plug for soldering onto printed circuit
Gerader Stecker zum Lötén auf gedruckter Schaltung**

**Elbow plug (90°) for soldering onto printed circuit,
Push-Pull self-latching coupling
Winkelstecker (90°) zum Lötén auf gedruckter Schaltung,
Push-Pull selbstverriegelnde Verbindung**

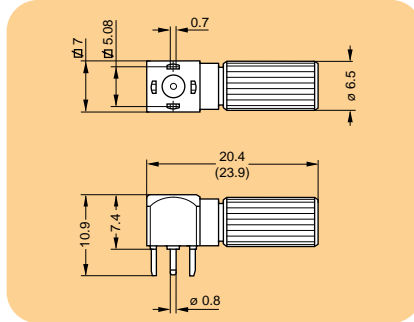
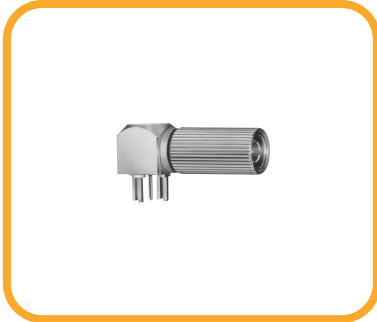
Part Number Bestell-Nummer	Cable group Kabelgruppe	Housing finish Körperbehandlung	Cable assembly Kabelmontage	Panel hole or printed circuit Bohrung der Frontpl. oder g. S.
SAA.140.50.10000	-	Au	-	P4
SAA.130.50.10000	-	Au	-	P13
SAA.131.50.10000	-	Au	-	P14
SAA.139.50.10600 SAA.139.75.10600	- -	Au Au	- -	P15 P15

Model / Modell

Elbow plug (90°) for soldering onto printed circuit, screw coupling Winkelstecker (90°) zum Lötén auf gedruckter Schaltung, Verbindung mit Schrauben



Straight plug for crimping, floating fixing Gerader Stecker zum Crimpen, Befestigung mit radialem Spielraum

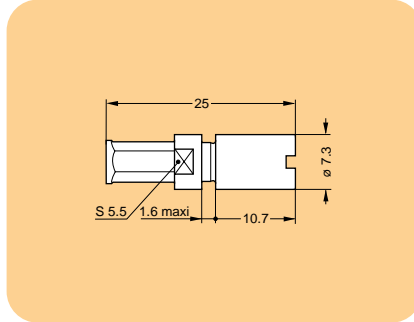
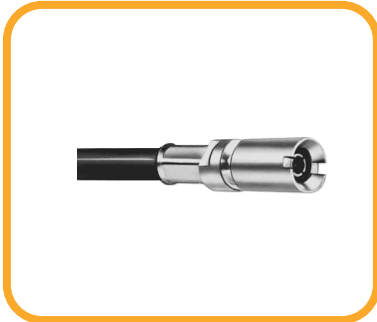

Available with 75 Ω impedance / Mit 75 Ω Impedanz verfügbar

Straight plug for crimping, floating fixing Gerader Stecker zum Crimpen, Befestigung mit radialem Spielraum

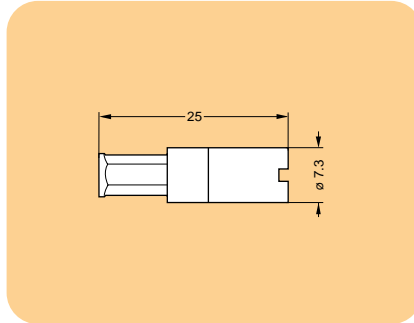
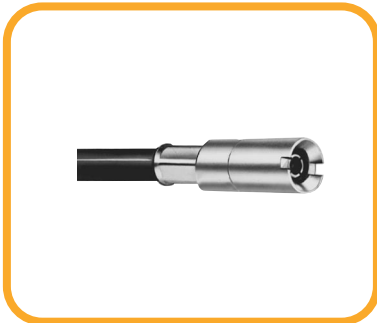

Available with 75 Ω impedance / Mit 75 Ω Impedanz verfügbar

Straight plug for crimping, Push-Pull self-latching coupling Gerader Stecker zum Crimpen, Push-Pull selbstverriegelnde Verbindung

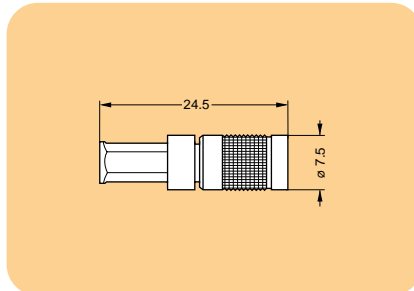

Available with 75 Ω impedance / Mit 75 Ω Impedanz verfügbar

Part Number Bestell-Nummer	Cable group Kabelgruppe	Housing finish Körperbehandlung	Cable assembly Kabelmontage	Panel hole or printed circuit Bohrung der Frontpl. oder g. S.
SAA.138.50.10600	-	Au	-	P15
SAA.138.75.10600	-	Au	-	P15
SAA.155.50.20028	1-2	Ni	M3	P2
SAA.155.50.20035	3	Ni	M3	P2
SAA.155.50.20041	4-5-6	Ni	M3	P2
SAA.155.50.20046	10	Ni	M3	P2
SAA.155.50.20048	7	Ni	M3	P2
SAA.155.50.20050	8	Ni	M3	P2
SAA.155.50.20061	9	Ni	M3	P2
SAA.156.50.20028	1-2	Ni	M3	-
SAA.156.50.20035	3	Ni	M3	-
SAA.156.50.20041	4-5-6	Ni	M3	-
SAA.156.50.20048	7	Ni	M3	-
SAA.156.50.20050	8	Ni	M3	-
SAA.156.50.20061	9	Ni	M3	-
SAA.189.50.20122	0	Ni	M4	-
SAA.189.50.20128	1	Ni	M4	-
SAA.189.50.20129	2	Ni	M4	-
SAA.189.50.20135	3	Ni	M4	-
SAA.189.50.20140	11	Ni	M4	-
SAA.189.50.20141	4	Ni	M4	-
SAA.189.50.20142	5	Ni	M4	-
SAA.189.50.20143	6	Ni	M4	-
SAA.189.50.20146	10	Ni	M4	-
SAA.189.50.20148	7	Ni	M4	-
SAA.189.50.20150	8	Ni	M4	-
SAA.189.50.20161	9	Ni	M8	-

Model / Modell

Straight plug for crimping, screw coupling Gerader Stecker zum Crimpen, Verbindung mit Schrauben

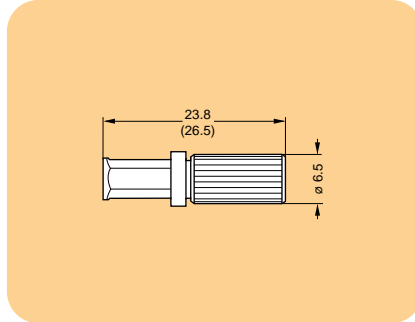
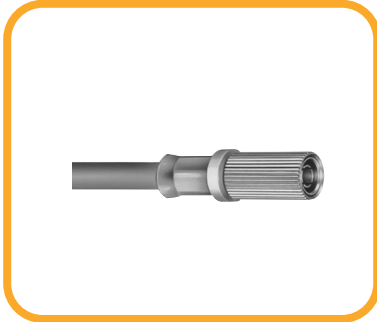

Available with 75 Ω impedance / Mit 75 Ω Impedanz verfügbar

Straight plug for soldering, Push-Pull self-latching coupling Gerader Stecker zum Löten, Push-Pull selbstverriegelnde Verbindung

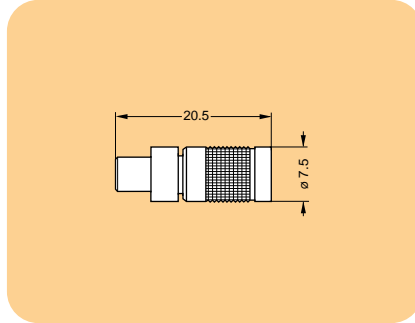
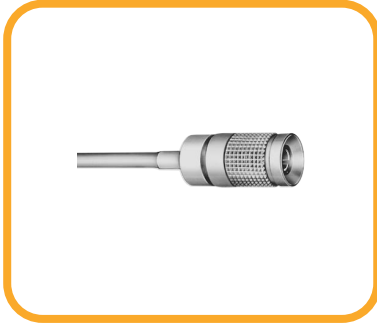

Available with 75 Ω impedance / Mit 75 Ω Impedanz verfügbar

Elbow plug (45°) for crimping, floating fixing Winkelstecker (45°) zum Crimpen, Befestigung mit radialem Spielraum

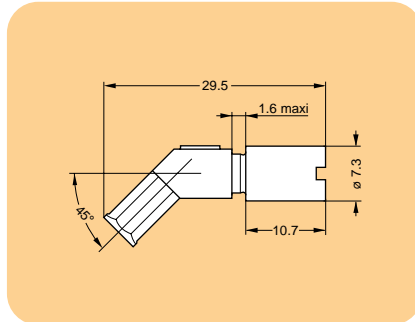
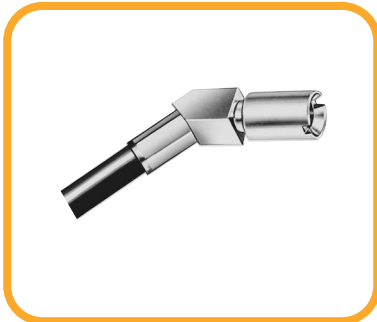

Available with 75 Ω impedance / Mit 75 Ω Impedanz verfügbar

Elbow plug (45°) for crimping, Push-Pull self-latching coupling Winkelstecker (45°) zum Crimpen, Push-Pull selbstverriegelnde Verbindung

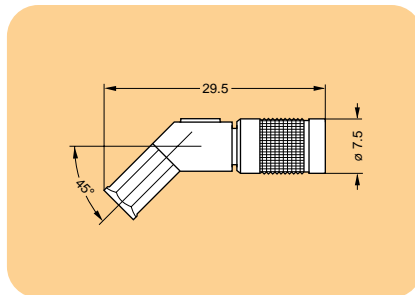
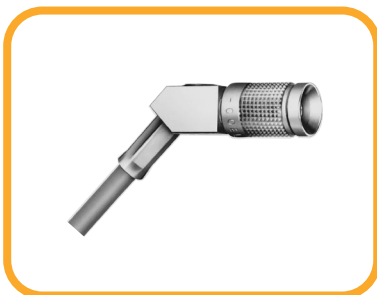

Available with 75 Ω impedance / Mit 75 Ω Impedanz verfügbar

Part Number Bestell-Nummer	Cable group Kabelgruppe	Housing finish Körperbehandlung	Cable assembly Kabelmontage	Panel hole or printed circuit Bohrung der Frontpl. oder g. S.
SAA.188.50.20122	0	Ni	M3	-
SAA.188.50.20128	1-2	Ni	M3	-
SAA.188.50.20135	3	Ni	M3	-
SAA.188.50.20141	4-5-6	Ni	M3	-
SAA.188.50.20146	10	Ni	M3	-
SAA.188.50.20148	7	Ni	M3	-
SAA.188.50.20150	8	Ni	M3	-
SAA.188.50.20161	9	Ni	M3	-
SAA.182.50.20020	12	Ni	M7	-
SAA.182.50.20022	13	Ni	M7	-
SAA.165.50.20028	1-2	Ni	M1	P3
SAA.165.50.20035	3	Ni	M1	P3
SAA.165.50.20041	4-5-6	Ni	M1	P3
SAA.165.50.20046	10	Ni	M1	P3
SAA.165.50.20048	7	Ni	M1	P3
SAA.165.50.20050	8	Ni	M1	P3
SAA.165.50.20061	9	Ni	M1	P3
SAA.209.50.20028	1-2	Ni	M1	-
SAA.209.50.20035	3	Ni	M1	-
SAA.209.50.20041	4-5-6	Ni	M1	-
SAA.209.50.20046	10	Ni	M1	-
SAA.209.50.20048	7	Ni	M1	-
SAA.209.50.20050	8	Ni	M1	-
SAA.209.50.20061	9	Ni	M1	-

Model / Modell

Elbow plug (45°) for crimping, screw coupling Winkelstecker (45°) zum Crimpen, Verbindung mit Schrauben

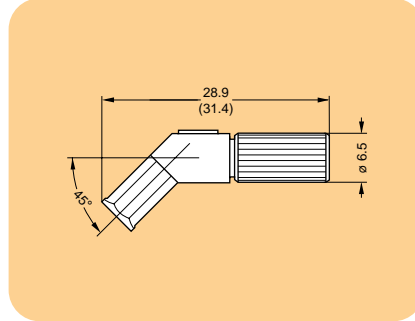
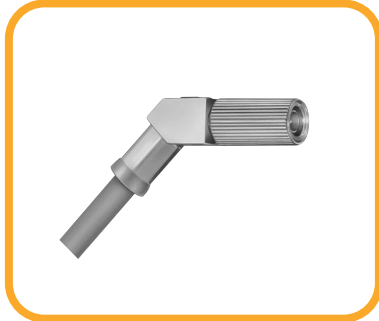

Available with 75 Ω impedance / Mit 75 Ω Impedanz verfügbar

Elbow plug (45°) for soldering, Push-Pull self-latching coupling Winkelstecker (45°) zum Lötén, Push-Pull selbstverriegelnde Verbindung

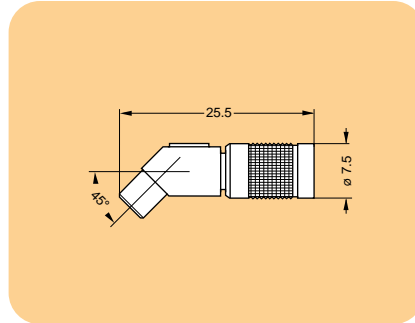
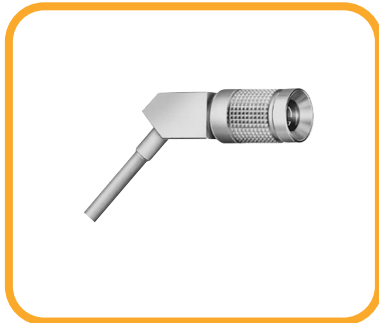

Available with 75 Ω impedance / Mit 75 Ω Impedanz verfügbar

Elbow plug (90°) for crimping, floating fixing Winkelstecker (90°) zum Crimpen, Befestigung mit radialem Spielraum

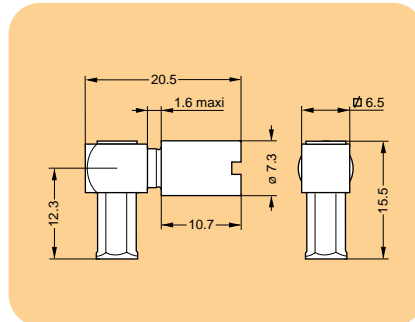
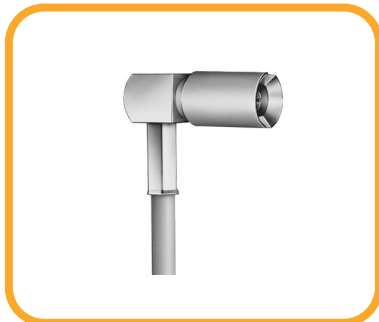

Available with 75 Ω impedance / Mit 75 Ω Impedanz verfügbar

Elbow plug (90°) for crimping, floating fixing Winkelstecker (90°) zum Crimpen, Befestigung mit radialem Spielraum

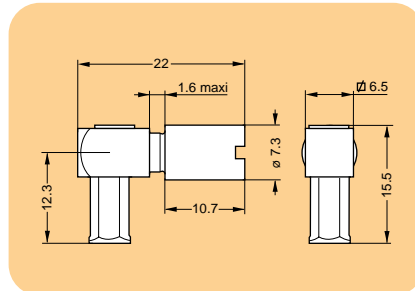
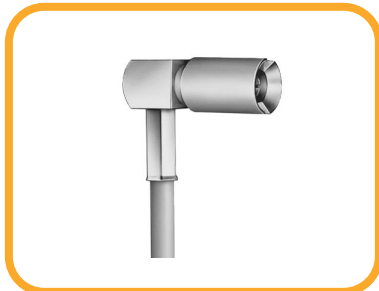

Available with 75 Ω impedance / Mit 75 Ω Impedanz verfügbar

Part Number Bestell-Nummer	Cable group Kabelgruppe	Housing finish Körperbehandlung	Cable assembly Kabelmontage	Panel hole or printed circuit Bohrung der Frontpl. oder g. S.
SAA.208.50.20028	1-2	Ni	M1	-
SAA.208.50.20035	3	Ni	M1	-
SAA.208.50.20041	4-5-6	Ni	M1	-
SAA.208.50.20046	10	Ni	M1	-
SAA.208.50.20048	7	Ni	M1	-
SAA.208.50.20050	8	Ni	M1	-
SAA.208.50.20061	9	Ni	M1	-
SAA.202.50.20020	12	Ni	M5	-
SAA.202.50.20022	13	Ni	M5	-
SAA.166.50.20028	1-2	Ni	M2	P1
SAA.166.50.20035	3	Ni	M2	P1
SAA.166.50.20041	4-5-6	Ni	M2	P1
SAA.166.50.20046	10	Ni	M2	P1
SAA.166.50.20048	7	Ni	M2	P1
SAA.166.50.20050	8	Ni	M2	P1
SAA.166.50.20061	9	Ni	M2	P1
SAA.167.50.20028	1-2	Ni	M2	P1
SAA.167.50.20035	3	Ni	M2	P1
SAA.167.50.20041	4-5-6	Ni	M2	P1
SAA.167.50.20046	10	Ni	M2	P1
SAA.167.50.20048	7	Ni	M2	P1
SAA.167.50.20050	8	Ni	M2	P1
SAA.167.50.20061	9	Ni	M2	P1

Model / Modell

Elbow plug (90°) for crimping, Push-Pull self-latching coupling Winkelstecker (90°) zum Crimpen, Push-Pull selbstverriegelnde Verbindung

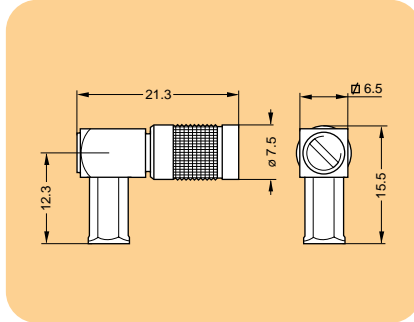

Available with 75 Ω impedance / Mit 75 Ω Impedanz verfügbar

Elbow plug (90°) for crimping, screw coupling Winkelstecker (90°) zum Crimpen, Verbindung mit Schrauben

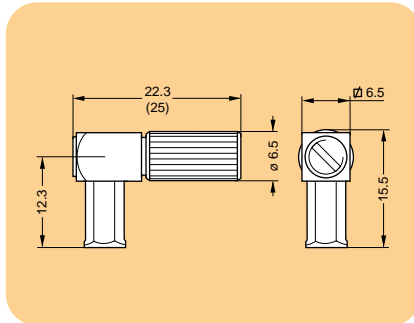

Available with 75 Ω impedance / Mit 75 Ω Impedanz verfügbar

Elbow plug (90°) for soldering, Push-Pull self-latching coupling Winkelstecker (90°) zum Lötén, Push-Pull selbstverriegelnde Verbindung

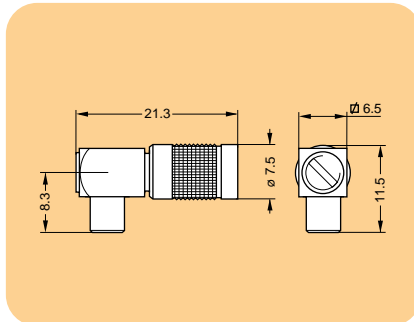
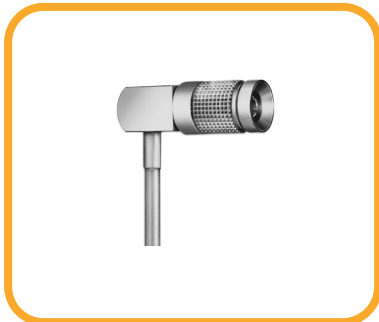

Fixed socket, nut fixing Gerade Apparatedose, Befestigung mit Mutter

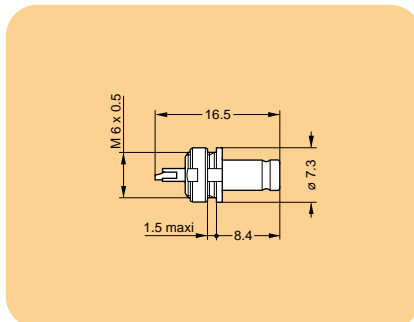
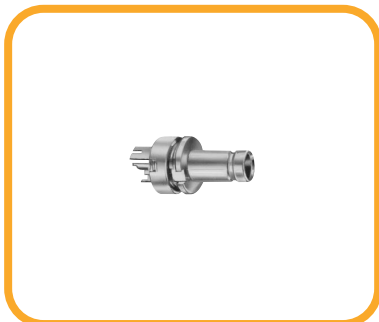

Part Number Bestell-Nummer	Cable group Kabelgruppe	Housing finish Körperbehandlung	Cable assembly Kabelmontage	Panel hole or printed circuit Bohrung der Frontplatte oder G. S.
SAA.199.50.20028	1-2	Ni	M2	-
SAA.199.50.20035	3	Ni	M2	-
SAA.199.50.20041	4-5-6	Ni	M2	-
SAA.199.50.20046	10	Ni	M2	-
SAA.199.50.20048	7	Ni	M2	-
SAA.199.50.20050	8	Ni	M2	-
SAA.199.50.20061	9	Ni	M2	-
SAA.198.50.20028	1-2	Ni	M2	-
SAA.198.50.20035	3	Ni	M2	-
SAA.198.50.20041	4-5-6	Ni	M2	-
SAA.198.50.20046	10	Ni	M2	-
SAA.198.50.20048	7	Ni	M2	-
SAA.198.50.20050	8	Ni	M2	-
SAA.198.50.20061	9	Ni	M2	-
SAA.192.50.20020	12	Ni	M6	-
SAA.192.50.20022	13	Ni	M6	-
SAA.192.75.20020	12	Ni	M6	-
SAA.192.75.20022	13	Ni	M6	-
SAA.300.50.10600	-	Au	-	P8

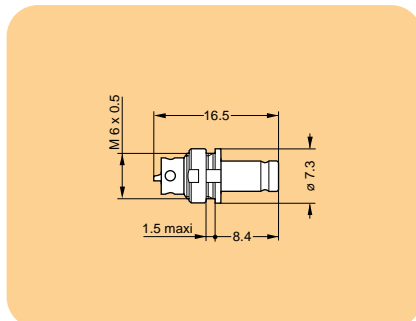
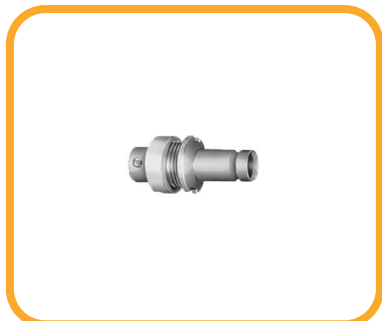
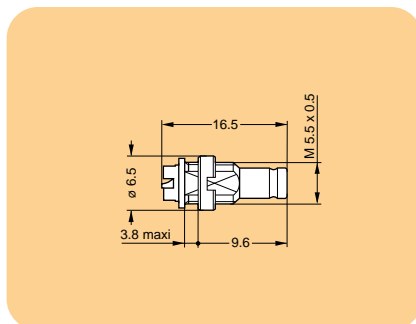
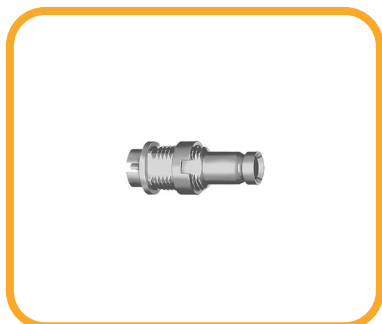
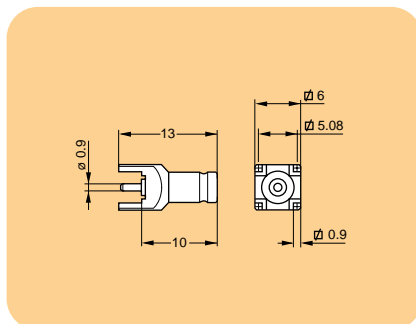
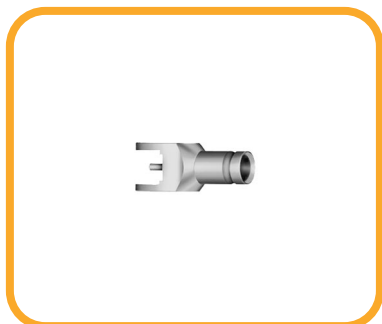
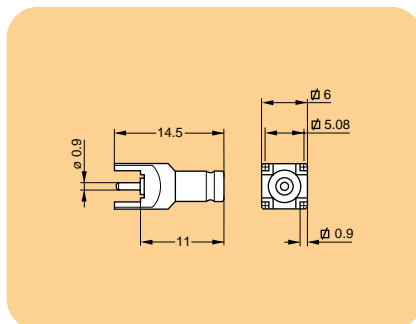
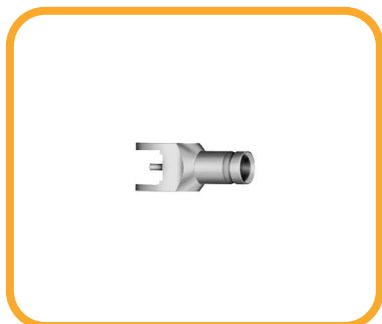
Model / Modell
**Straight socket, nut fixing
Gerade Apparatedose, Befestigung mit Mutter**

**Straight socket, front nut fixing
Gerade Apparatedose, Befestigung mit Frontmutter**

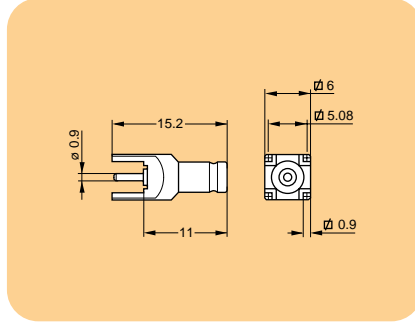
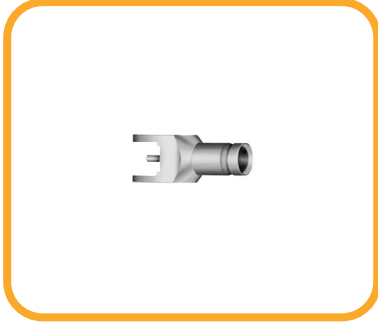
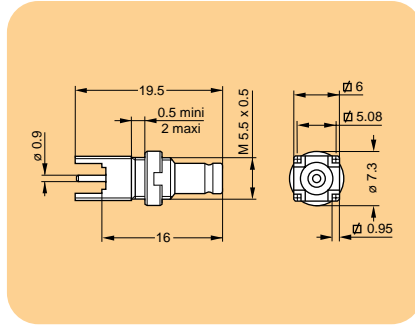
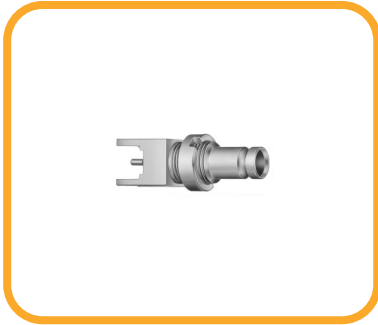
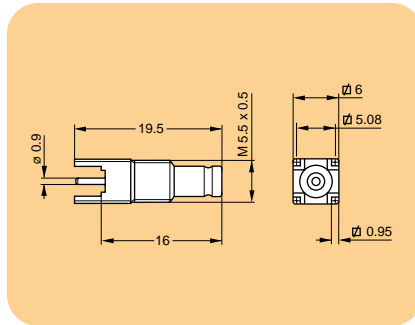
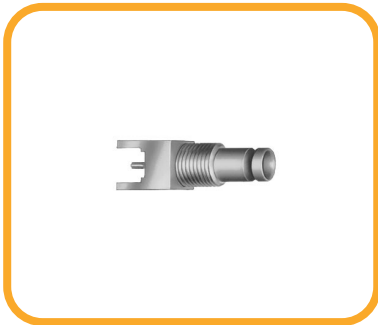
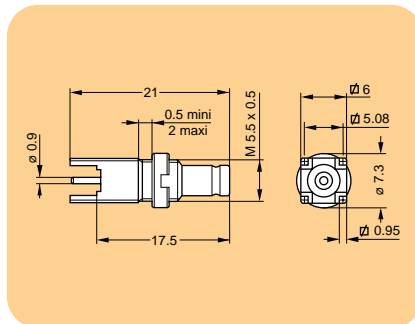
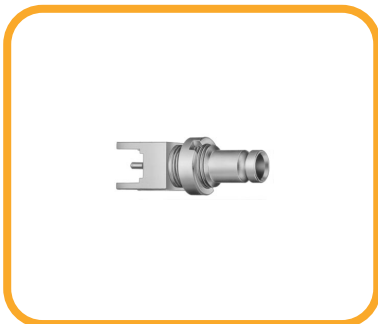
**Straight socket for soldering onto printed circuit
Gerade Apparatedose zum Löten auf gedruckter Schaltung**

**Straight socket for soldering onto printed circuit
Gerade Apparatedose zum Löten auf gedruckter Schaltung**

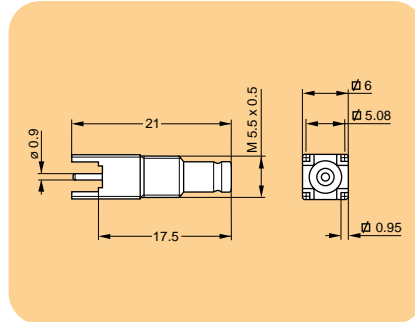
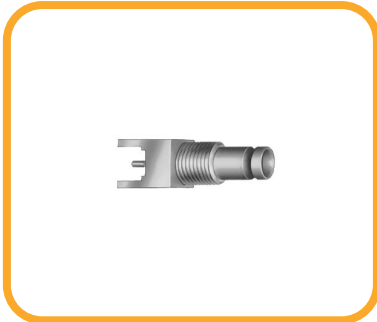
Part Number Bestell-Nummer	Cable group Kabelgruppe	Housing finish Körperbehandlung	Cable assembly Kabelmontage	Panel hole or printed circuit Bohrung der Frontpl. oder g. S.
SAA.301.50.10600	-	Au	-	P8
SAA.305.50.10600	-	Au	-	P6
SAA.360.50.10600	-	Au	-	P14
SAA.361.50.10600	-	Au	-	P14

Model / Modell
**Straight socket for soldering onto printed circuit
Gerade Apparatedose zum Lötén auf gedruckter Schaltung**

**Straight socket, nut fixing, for soldering onto printed circuit
Gerade Apparatedose, Befestigung mit Mutter,
zum Lötén auf gedruckter Schaltung**

**Straight socket for soldering onto printed circuit
Gerade Apparatedose zum Lötén auf gedruckter Schaltung**

**Straight socket, nut fixing, for soldering onto printed circuit
Gerade Apparatedose, Befestigung mit Mutter,
zum Lötén auf gedruckter Schaltung**

Part Number Bestell-Nummer	Cable group Kabelgruppe	Housing finish Körperbehandlung	Cable assembly Kabelmontage	Panel hole or printed circuit Bohrung der Frontpl. oder g. S.
SAA.362.50.10600	-	Au	-	P14
SAA.350.50.10600 SAA.350.75.10600	- -	Au Au	- -	P5-P14 P5-P14
SAA.350.50.10609 SAA.350.75.10609	- -	Au Au	- -	P14 P14
SAA.351.50.10600 SAA.351.75.10600	- -	Au Au	- -	P5-P14 P5-P14

Model / Modell
**Straight socket for soldering onto printed circuit
Gerade Apparatedose zum Löten auf gedruckter Schaltung**

 Part Number
Bestell-Nummer

 Cable group
Kabelgruppe

 Housing finish
Körperbehandlung

 Cable assembly
Kabelmontage

 Panel hole or printed circuit
Bohrung der Frontpl. oder g. S.

 SAA.351.50.10609
SAA.351.75.10609

-

 Au
Au

-

 P14
P14

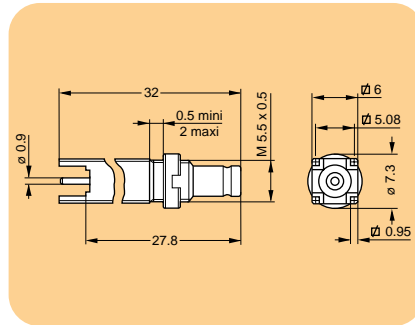
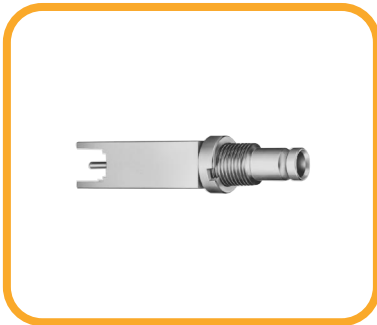
**Straight socket, nut fixing, for soldering onto printed circuit
Gerade Apparatedose, Befestigung mit Mutter,
zum Löten auf gedruckter Schaltung**

 SAA.352.50.10600
SAA.352.75.10600

-

 Au
Au

-

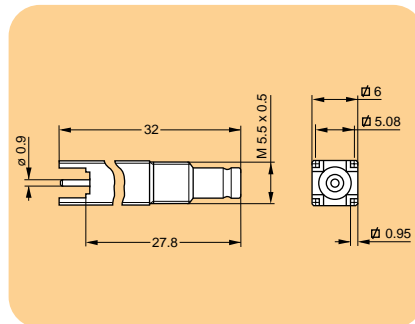
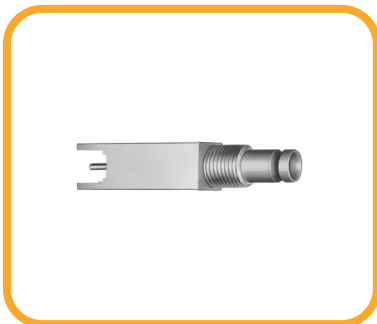
 P5-P14
P5-P14

**Straight socket for soldering onto printed circuit
Gerade Apparatedose zum Löten auf gedruckter Schaltung**

 SAA.352.50.10609
SAA.352.75.10609

-

 Au
Au

-

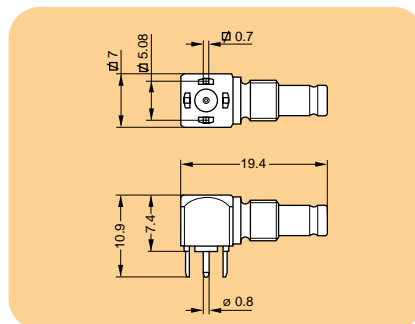
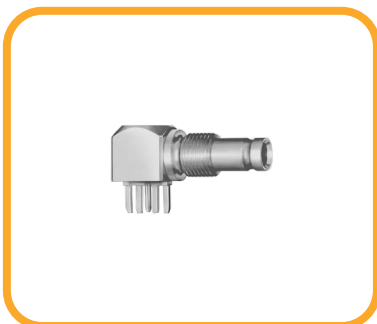
 P14
P14

**Elbow socket (90°) for soldering onto printed circuit
Winkeldose (90°) zum Löten auf gedruckter Schaltung**

 SAA.366.50.10600
SAA.366.75.10600

-

 Au
Au

-

 P15
P15

Model / Modell

Elbow socket (90°) for soldering onto printed circuit Winkeldose (90°) zum Lötén auf gedruckter Schaltung

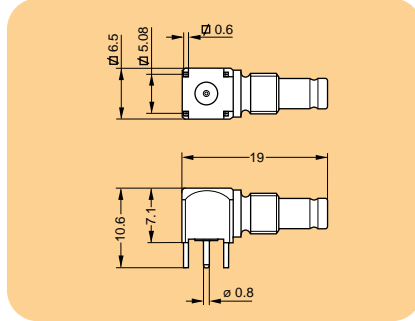
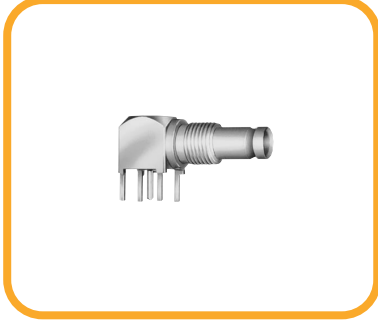

Fixed socket for crimping, floating fixing Gerade Apparatedose zum Crimpen, Befestigung mit radialem Spielraum

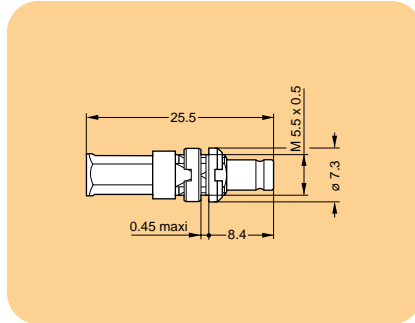
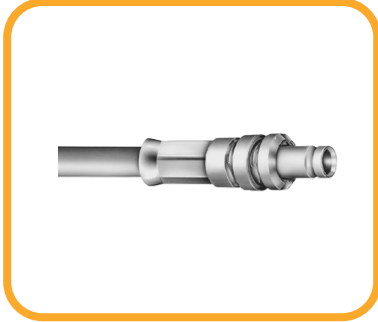

Available with 75 Ω impedance / Mit 75 Ω Impedanz verfügbar

Fixed socket for crimping, floating fixing Gerade Apparatedose zum Crimpen, Befestigung mit radialem Spielraum

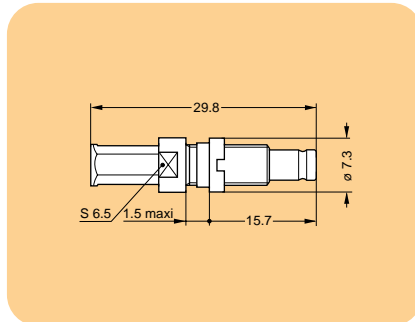
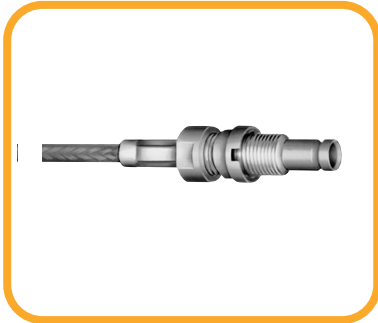

Available with 75 Ω impedance / Mit 75 Ω Impedanz verfügbar

Straight socket for crimping Gerade Apparatedose zum Crimpen

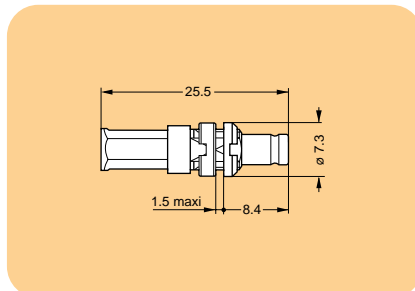
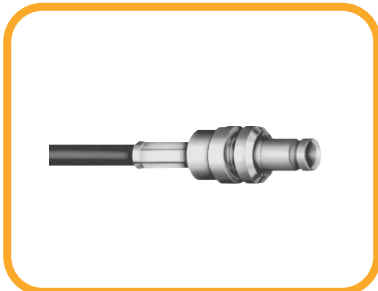

Available with 75 Ω impedance / Mit 75 Ω Impedanz verfügbar

Part Number Bestell-Nummer	Cable group Kabelgruppe	Housing finish Körperbehandlung	Cable assembly Kabelmontage	Panel hole or printed circuit Bohrung der Frontpl. oder g. S.
SAA.367.50.10600	-	Au	-	P14
SAA.367.75.10600	-	Au	-	P14
SAA.324.50.10622	0	Au	M3	P11
SAA.324.50.10628	1-2	Au	M3	P11
SAA.324.50.10635	3	Au	M3	P11
SAA.324.50.10641	4-5-6	Au	M3	P11
SAA.324.50.10648	7	Au	M3	P11
SAA.324.50.10650	8	Au	M3	P11
SAA.325.50.10622	0	Au	M3	P12
SAA.325.50.10628	1-2	Au	M3	P12
SAA.325.50.10635	3	Au	M3	P12
SAA.325.50.10641	4-5-6	Au	M3	P12
SAA.325.50.10648	7	Au	M3	P12
SAA.325.50.10650	8	Au	M3	P12
SAA.325.50.10661	9	Au	M3	P12
SAA.326.50.10622	0	Au	M3	P7
SAA.326.50.10628	1-2	Au	M3	P7
SAA.326.50.10635	3	Au	M3	P7
SAA.326.50.10641	4-5-6	Au	M3	P7
SAA.326.50.10648	7	Au	M3	P7
SAA.326.50.10650	8	Au	M3	P7
SAA.326.50.10661	9	Au	M3	P7

Model / Modell

Straight socket for soldering Gerade Apparatedose zum Löten

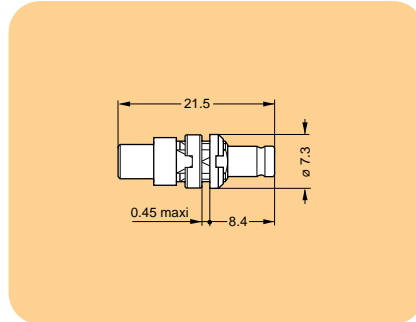
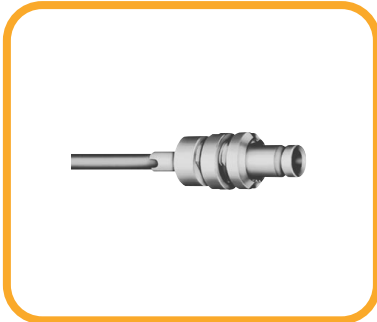

Available with 75 Ω impedance / Mit 75 Ω Impedanz verfügbar

Elbow socket (45°) for crimping, floating fixing Winkeldose (45°) zum Crimpen, Befestigung mit radialem Spielraum

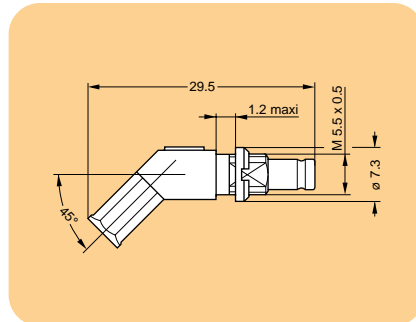
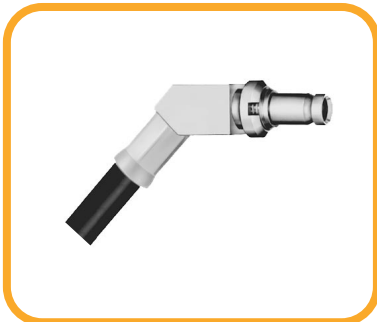

Available with 75 Ω impedance / Mit 75 Ω Impedanz verfügbar

Elbow socket (45°) for soldering Winkeldose (45°) zum Löten

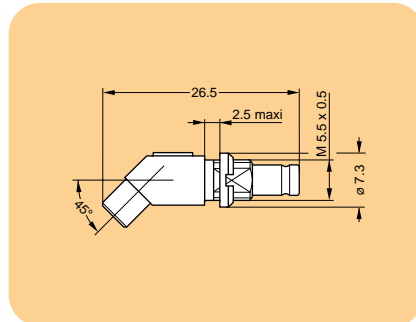
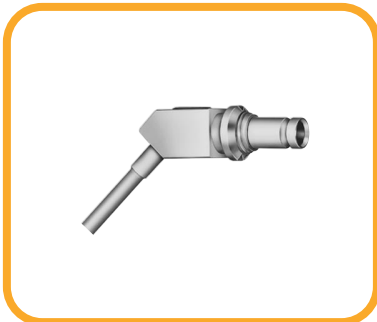

Elbow socket (90°) for crimping, floating fixing Winkeldose (90°) zum Crimpen, Befestigung mit radialem Spielraum

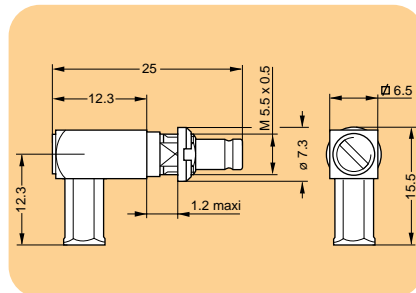
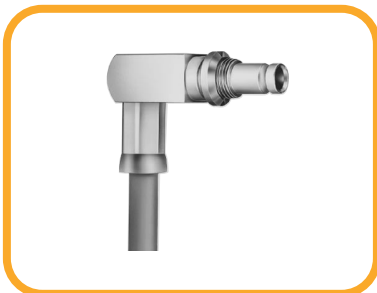

Available with 75 Ω impedance / Mit 75 Ω Impedanz verfügbar

Part Number Bestell-Nummer	Cable group Kabelgruppe	Housing finish Körperbehandlung	Cable assembly Kabelmontage	Panel hole or printed circuit Bohrung der Frontpl. oder g. S.
SAA.320.50.10620	12	Au	M7	P7
SAA.320.50.10622	13	Au	M7	P7
SAA.340.50.10628	1-2	Au	M1	P3
SAA.340.50.10635	3	Au	M1	P3
SAA.340.50.10641	4-5-6	Au	M1	P3
SAA.340.50.10648	7	Au	M1	P3
SAA.340.50.10650	8	Au	M1	P3
SAA.340.50.10661	9	Au	M1	P3
SAA.345.50.10620	12	Au	M5	P3
SAA.345.50.10622	13	Au	M5	P3
SAA.345.75.10620	12	Au	M5	P3
SAA.345.75.10622	13	Au	M5	P3
SAA.310.50.10628	1-2	Au	M2	P9
SAA.310.50.10635	3	Au	M2	P9
SAA.310.50.10641	4-5-6	Au	M2	P9
SAA.310.50.10648	7	Au	M2	P9
SAA.310.50.10650	8	Au	M2	P9
SAA.310.50.10661	9	Au	M2	P9

Model / Modell

Elbow socket (90°) for crimping Winkeldose (90°) zum Crimpen

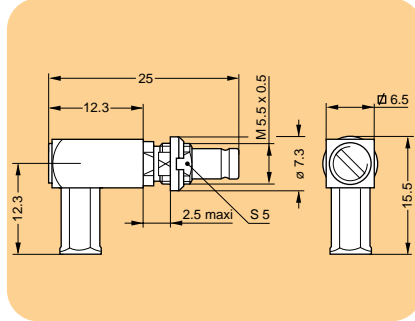

Available with 75 Ω impedance / Mit 75 Ω Impedanz verfügbar

Elbow socket (90°) for crimping Winkeldose (90°) zum Crimpen

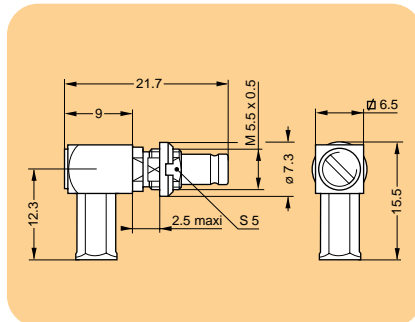
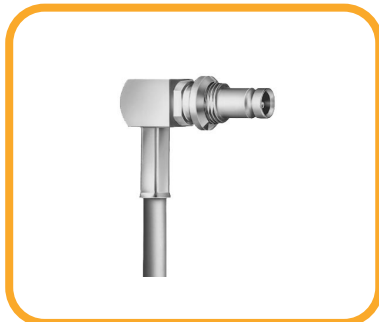

Available with 75 Ω impedance / Mit 75 Ω Impedanz verfügbar

Elbow socket (90°) for soldering Winkeldose (90°) zum Löten

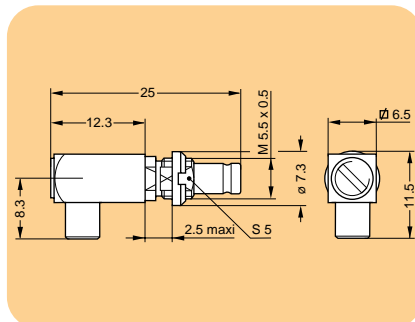

Straight plug with resistance (50 or 75 Ω) / 0.6 W Gerader Stecker mit Widerstand (50 oder 75 Ω) / 0.6 W

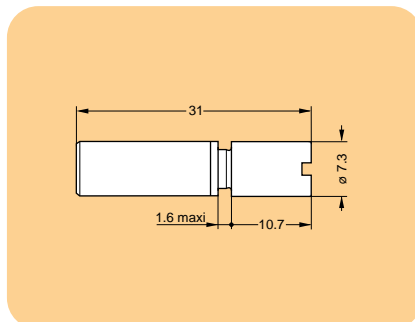

Part Number Bestell-Nummer	Cable group Kabelgruppe	Housing finish Körperbehandlung	Cable assembly Kabelmontage	Panel hole or printed circuit Bohrung der Frontpl. oder g. S.
SAA.311.50.10628	1-2	Au	M2	P10
SAA.311.50.10635	3	Au	M2	P10
SAA.311.50.10641	4-5-6	Au	M2	P10
SAA.311.50.10648	7	Au	M2	P10
SAA.311.50.10650	8	Au	M2	P10
SAA.311.50.10661	9	Au	M2	P10
SAA.312.50.10628	1-2	Au	M2	P10
SAA.312.50.10635	3	Au	M2	P10
SAA.312.50.10641	4-5-6	Au	M2	P10
SAA.312.50.10648	7	Au	M2	P10
SAA.312.50.10650	8	Au	M2	P10
SAA.312.50.10661	9	Au	M2	P10
SAA.315.50.10620	12	Au	M6	P10
SAA.315.50.10622	13	Au	M6	P10
SAA.315.75.10620	12	Au	M6	P10
SAA.315.75.10622	13	Au	M6	P10
	Resistance (Ω) Widerstand (Ω)			
SAA.171.50.20001	50	Ni	-	-
SAA.171.75.20001	75	Ni	-	-

Model / Modell

**Straight plug with resistance (50 or 75 Ω) / 0.6 W,
Push-Pull self-latching coupling**
**Gerader Stecker mit Widerstand (50 oder 75 Ω) / 0.6 W,
Push-Pull selbstverriegelnde Verbindung**

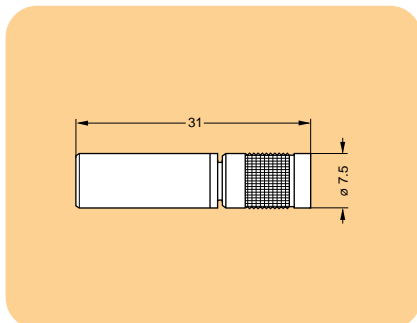

Straight socket with resistance (50 or 75 Ω) / 0.6 W
Gerade Apparatedose mit Widerstand (50 oder 75 Ω) / 0.6 W

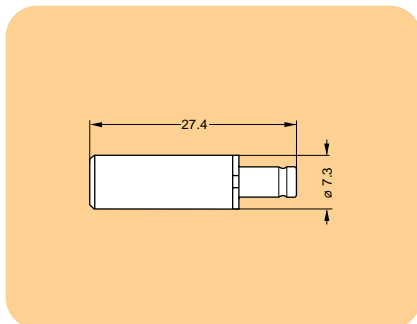
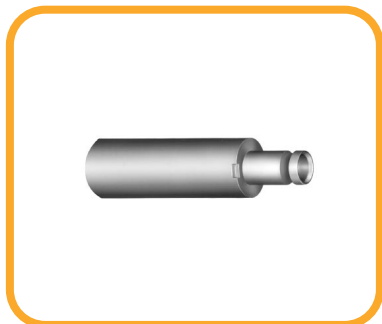

Straight male-female coupler, floating fixing
**Gerade Dose, Verbindung Stift-Buchse,
Befestigung mit radialem Spielraum**

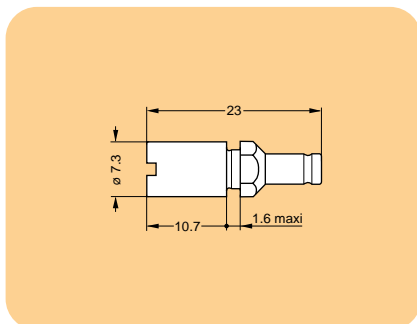
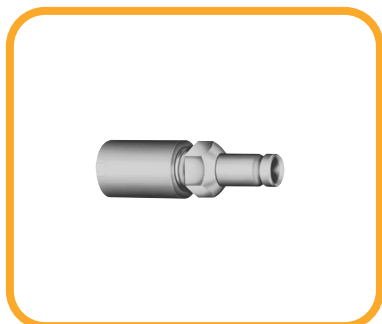

Straight male-male coupler
Gerade Kupplung, Verbindung Stift-Stift

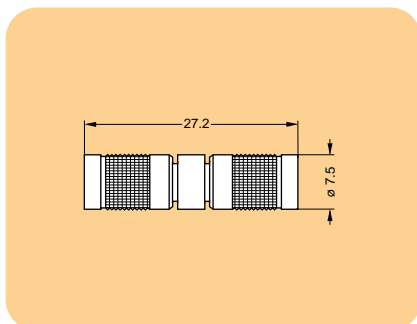
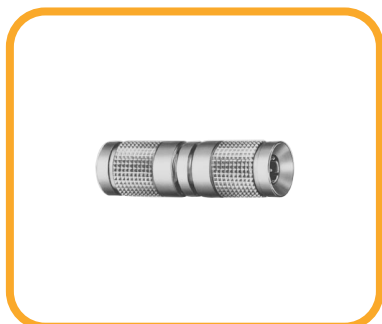

Part Number Bestell-Nummer	Resistance (Ω) Widerstand (Ω)	Housing finish Körperbehandlung	Cable assembly Kabelmontage	Panel hole or printed circuit Bohrung der Frontpl. oder g. S.
SAA.179.50.20001 SAA.179.75.20001	50 75	Ni Ni	- -	- -
SAA.371.50.10001 SAA.371.75.10001	50 75	Au Au	- -	- -
SAA.570.50.10500 SAA.570.75.10500	- -	Au Au	- -	P2 P2
SAA.589.50.20200 SAA.589.75.20200	- -	Ni Ni	- -	- -

Model / Modell

Straight male-female coupler Gerade Dose, Verbindung Stift-Buchse

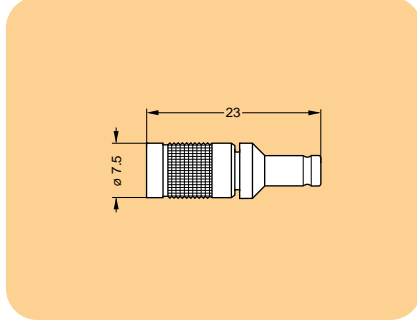
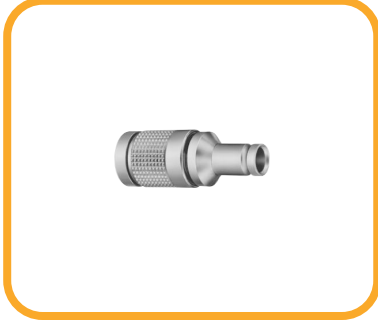

Male-male bridge plug, Push-Pull self-latching coupling Kupplungsstück, Verbindung Stift-Stift, Push-Pull selbstverriegelnde Verbindung

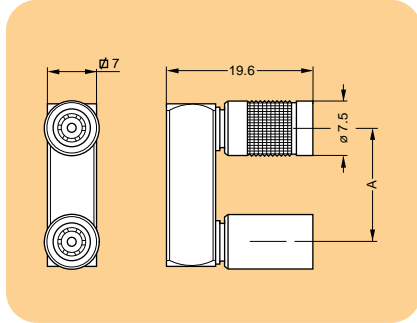
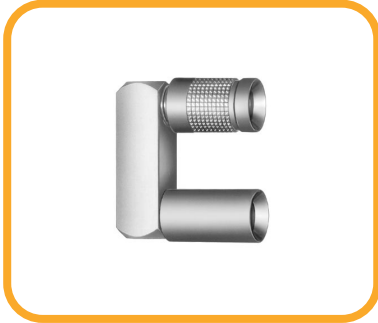

Available with 75 Ω impedance / Mit 75 Ω Impedanz verfügbar

Male-male bridge plug with monitoring socket Kupplungsstück mit Apparatedose als Ausgang

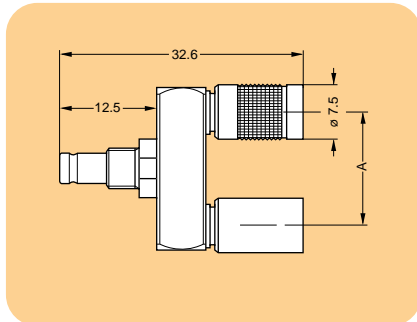
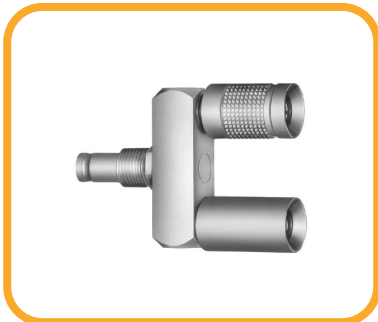

Available with 75 Ω impedance / Mit 75 Ω Impedanz verfügbar

Straight female-female coupler Gerade Kupplung, Verbindung Buchse-Buchse

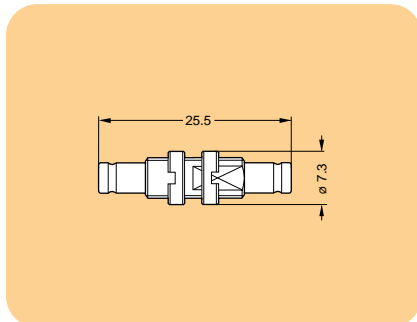
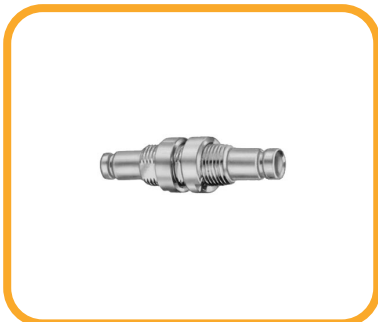

Part Number Bestell-Nummer	Dimensions (mm) Dimensionen (mm)	Housing finish Körperbehandlung	Cable assembly Kabelmontage	Panel hole or printed circuit Bohrung der Frontpl. oder g. S.
SAA.579.50.10500 SAA.579.75.10500	- -	Au Au	- -	- -
SAA.566.50.20010 SAA.566.50.20012 SAA.566.50.20015	A=10.2 A=12.5 A=15.0	Ni Ni Ni	- - -	- - -
SAA.569.50.20010 SAA.569.50.20012 SAA.569.50.20015	A=10.2 A=12.5 A=15.0	Ni Ni Ni	- - -	- - -
SAA.515.50.10800 SAA.515.75.10800	- -	Au Au	- -	P6 P6

Model / Modell

SAA socket and TAA plug adapter, Push-Pull coupling
Adapter SAA Apparatedose und TAA Stecker,
Push-Pull selbstverriegelnde Verbindung

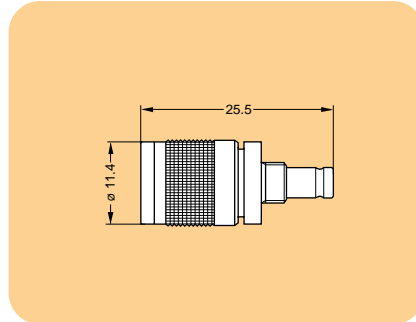

SAA plug and TAA socket adapter, Push-Pull coupling
Adapter SAA Stecker und TAA Apparatedose,
Push-Pull selbstverriegelnde Verbindung

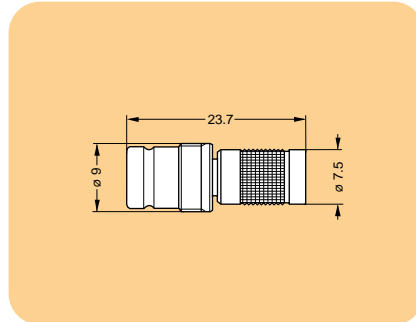
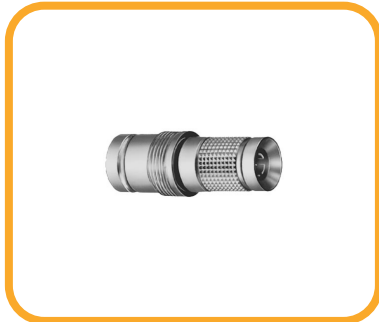

«T» form adapter for SAA plug and socket + SAA socket,
Push-Pull coupling
«T» Adapter, SAA Stecker und Apparatedose + SAA Apparatedose,
Push-Pull selbstverriegelnde Verbindung

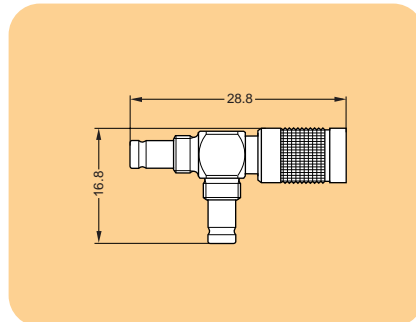

«T» form adapter, for SAA plug and socket + SAA socket,
screw coupling
«T» Adapter, SAA Stecker und Apparatedose + SAA Apparatedose,
Verbindung mit Schrauben

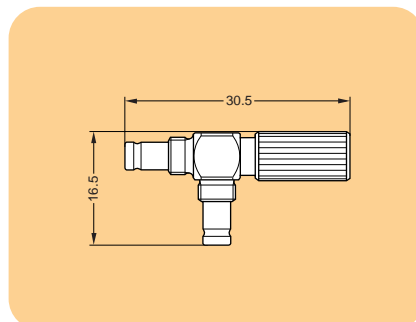

Part Number Bestell-Nummer	Cable group Kabelgruppe	Housing finish Körperbehandlung	Cable assembly Kabelmontage	Panel hole or printed circuit Bohrung der Frontpl. oder g. S.
SAA.750.75.10500	-	Au	-	-
SAA.757.75.10500	-	Au	-	-
SAA.599.75.10900	-	Au	-	-
SAA.598.75.10900	-	Au	-	-

Accessories / Zubehör

Cable sleeve (strain relief) Knickschutztülle

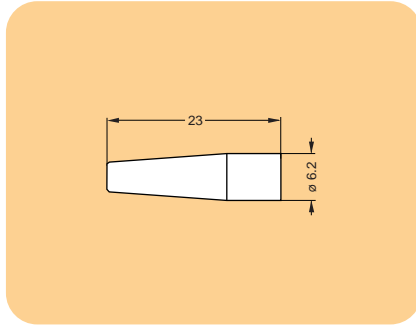
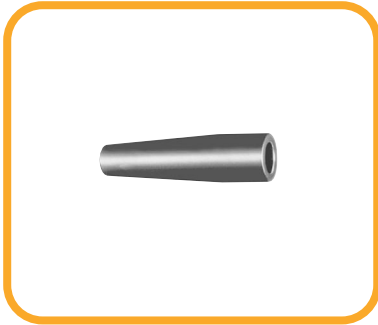

Part number Bestell-Nummer	Cable group Kabelgruppe
SAA.850.00.2325 G	1-2-3
SAA.850.00.2328 G	4

Material: Desmopan
Material: Desmopan

Code Bez.	Colour Farbe
A	blue blau
B	white weiß
G	grey grau
J	yellow gelb
M	brown braun
N	black schwarz
R	red rot
S	orange orange
V	green grün

The last letter 'G' of the part number indicates the grey colour of the cable sleeve. For other colours, see the above table and change the last letter 'G' of the part number to the corresponding letter.

Um eine andersfarbige Tülle zu erhalten, ist die in obenstehender Tabelle angegebene Farbe zu wählen und der letzte Buchstabe der Bestell-Nummer 'G' durch den der gewählten Farbe entsprechenden Buchstaben zu ersetzen.

M: Cable assembly / Kabelmontage

Straight connectors for crimping (solder contact)

Gerade Stecker zum Crimpen (Lötkontakt)

- Strip cable to dimensions shown in adjacent table. Slide crimp ferrule ① onto cable.

Kabel gemäß den Angaben der nachstehenden Tabelle abisolieren. Kabel in die Crimphülse ① einführen.

- Fit cable conductor into contact ②, tin solder through the side hole and remove excess of soldering. Expand screen.

Kabelleiter in den Kontakt ② einführen. Durch die seitliche Öffnung zinnlöten. Den Lötüberschuss wegnehmen. Die Abschirmung ausweiten.

- Slide cable into housing ③ until dielectric butts up against insulator. Slide crimp ferrule over screen until it reaches housing. Crimp with corresponding crimping tool.

Das Kabel in den Steckerkörper ③ bis zum Anschlag des Dielektrikums gegen die Isolationshülse einführen. Die Crimphülse über den Kabelschirm bis zum Anschlag gegen den Steckerkörper schieben. Mit der entsprechenden Zange crimpen.

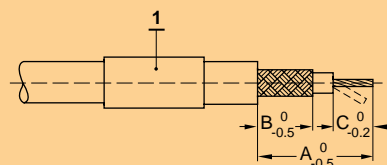

M	Dimensions Dimensionen (mm)		
	A	B	C
M1	12.5	6	3.5
M2	10.5	6	3.5
M3	10.0	6	2.5

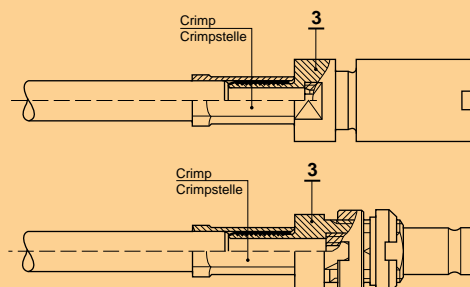
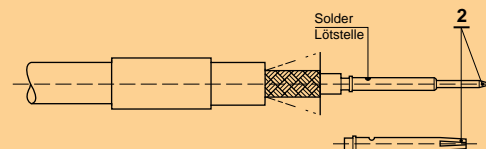

Elbow connectors for crimping (solder contact)
Winkelstecker zum Crimpen (Lötkontakt)

- 4** After operation **1-2-3**, bend the conductor to 45°. Expand screen. Push cable into the housing **3** until dielectric butts up against insulating sleeve **4**. Push conductor into the contact slot and tin solder. Slide crimp ferrule over screen until it reaches housing. Crimp with corresponding crimping tool. Screw in flat screw **5**.

Nach der Ausführung der Anleitungen **1-2-3** den Kabelleiter um 45° biegen. Die Abschirmung ausweiten. Das Kabel in den Steckerkörper **3** bis zum Anschlag des Dielektrikums gegen die Isolationshülse **4** einführen. Kabelleiter in die Kontaktöffnung einführen und zinnlöten. Die Crimphülse über den Kabelschirm bis zum Anschlag gegen den Steckerkörper schieben. Mit der entsprechenden Zange crimpen. Das Loch mit der Schraube **5** schließen.

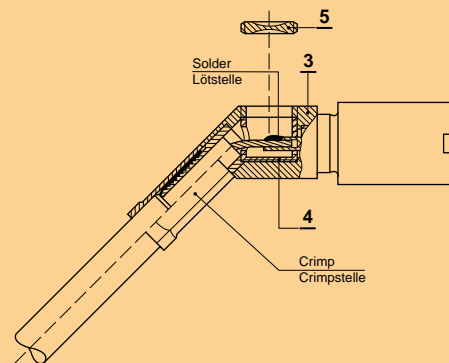

- 5** After operation **1-2-3**, expand screen. Push cable into the housing **3**. Make sure that conductor is correctly located in the contact slot. Solder through the hole. Slide crimp ferrule over screen until it reaches housing. Crimp with corresponding crimping tool. Screw in flat screw **5**.

Nach der Ausführung der Anleitungen **1-2-3** die Abschirmung ausweiten. Das Kabel in den Steckerkörper **3** einführen. Kontrollieren, ob der Leiter richtig in die Kontaktöffnung eingeführt ist und durch das Loch zinnlöten. Die Crimphülse über den Kabelschirm bis zum Anschlag gegen den Steckerkörper schieben. Mit der entsprechenden Zange crimpen. Das Loch mit der Schraube **5** schließen.

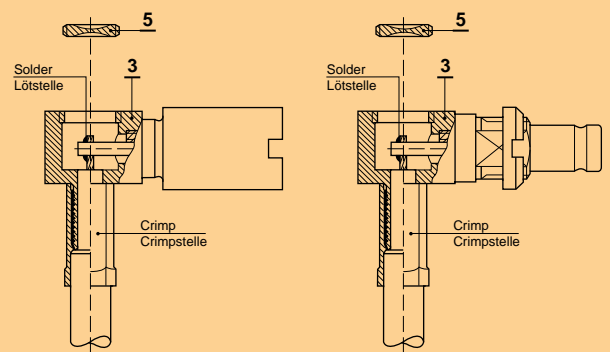
Straight connectors for crimping (crimp contact)
Gerade Stecker zum Crimpen (Crimpkontakt)

- 1** Strip cable to dimensions shown in adjacent table. Slide crimp ferrule **1** onto cable.

Kabel gemäß den Angaben der nachstehenden Tabelle abisolieren. Kabel in die Crimphülse **1** einführen.

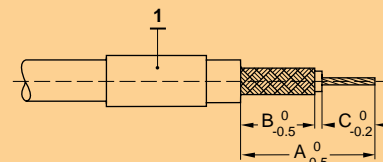

M	Dimensions Dimensionen (mm)		
	A	B	C
M4	12.5	6	4.9
M8	7.8	6	1.8

- 2** Fit cable conductor into contact **2**. Crimp using the corresponding crimping tool. Expand screen.

Kabelleiter in den Kontakt **2** einführen. Mit der entsprechenden Zange crimpen. Die Abschirmung ausweiten.

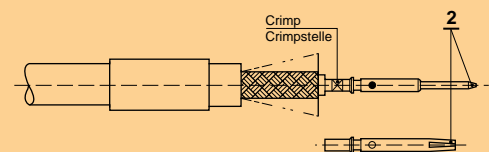

- 3** Slide cable into housing **3** until dielectric butts up against insulator. Gently pull the cable to check retention of contact within the insulator. Slide crimp ferrule over screen until it reaches housing. Crimp with corresponding crimping tool.

Das Kabel in den Steckerkörper **3** bis zum Anschlag des Dielektrikums gegen das Isolierteil einführen. Leicht mit dem Kabel zurückziehen, um den richtigen Sitz des Kontakts im Isolierteil zu prüfen. Die Crimphülse über den Kabelschirm bis zum Anschlag gegen den Steckerkörper schieben. Mit der entsprechenden Zange crimpen.

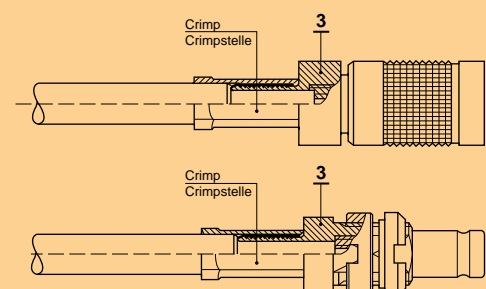

Straight connectors for soldering (semi-rigid cable)

Gerade Stecker zum Löten (semi-rigid Kabel)

- 1** Strip cable to dimensions shown in adjacent table.

Kabel gemäß den Angaben der nachstehenden Tabelle abisolieren.

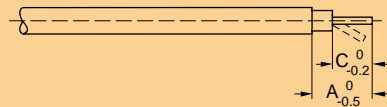

M	Dimensions Dimensionen (mm)	
M5	11	3.5
M6	9	3.5
M7	9	2.5

- 2** Fit cable conductor into contact ② tin solder and remove excess of soldering.

Kabelleiter in den Kontakt ② einführen, zinnlöten, und den Lötüberschuss wegnehmen.

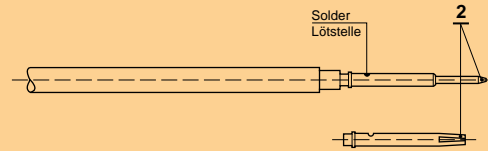

- 3** Slide cable into housing ③ until dielectric butts up against insulator. Solder the outer screen to the connector.

Das Kabel in dem Steckerkörper ③ bis zum Anschlag des Dielektrikums gegen das Isolierteil einführen. Die Außenschirmung mit dem Stecker löten.

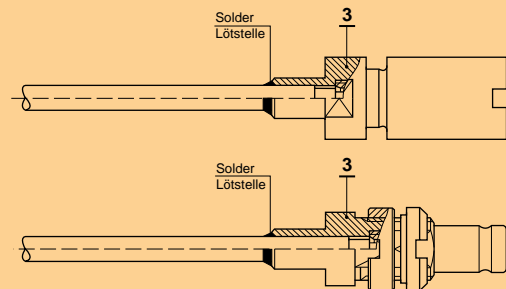

Elbow connectors for soldering (semi-rigid cable)

Winkelstecker zum Löten (semi-rigid Kabel)

- 4** After operation 1-2-3 bend the conductor to 45°. Slide cable into housing ③ until dielectric butts up against insulating sleeve ④. Fit conductor into contact slot and tin solder. Solder the outer screen of cable to connector. Screw in flat screw ⑤.

Nach der Ausführung der Anleitungen 1-2-3 den Leiter um 45° biegen. Das Kabel in der Steckerkörper ③ bis zum Anschlag des Dielektrikums gegen die Isolationshülse ④ einführen. Kabelleiter in die Kontaktöffnung einführen und zinnlöten. Die Außenschirmung mit dem Stecker löten. Das Loch mit der Schraube ⑤ schließen.

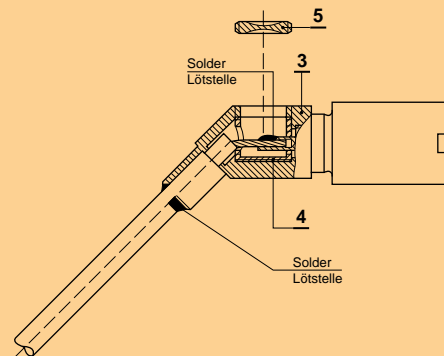

- 5** After operation 1-2-3, slide cable into the housing ③. Make sure that the conductor is correctly located in the contact slot. Solder contact through its slot. Solder the outer screen of cable to connector. Screw in flat screw ⑤.

Nach der Ausführung der Anleitungen 1-2-3 das Kabel in dem Steckerkörper ③ einführen. Kontrollieren, ob der Leiter richtig in die Kontaktöffnung eingeführt ist und durch das Loch löten. Die Außenschirmung des Kabels mit dem Stecker löten. Das Loch mit der Schraube ⑤ schließen.

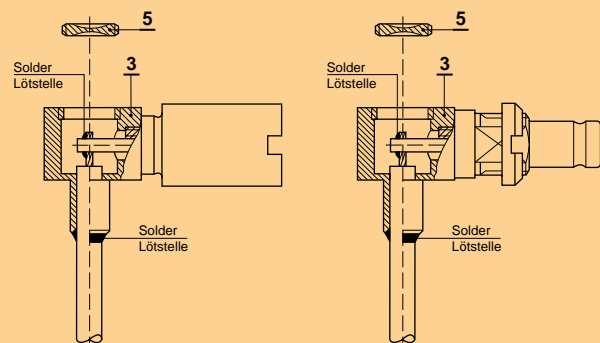

P: Drilling pattern / Bohrungsplan

Panel holes Bohrung der Frontplatte

P	Dimensions Dimensionen (mm)			
	A	B	C	D
P1	5.7	-	8.5	-
P2	5.7	-	8.5	7.5
P3	5.7	-	8.5	10.0
P4	6.7	-	7.5	7.5
P5	5.6	-	7.5	7.5
P6	5.6	4.5	7.0	7.0
P7	5.6	4.5	7.5	7.5
P8	6.1	-	8.5	8.5
P9	6.1	-	7.5	-
P10	6.1	5.1	7.5	-
P11	6.2	-	7.5	7.5
P12	6.7	-	7.5	7.5

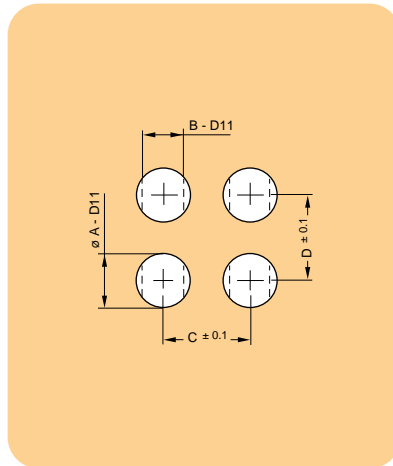

Printed circuit holes Bohrung der gedruckten Schaltung

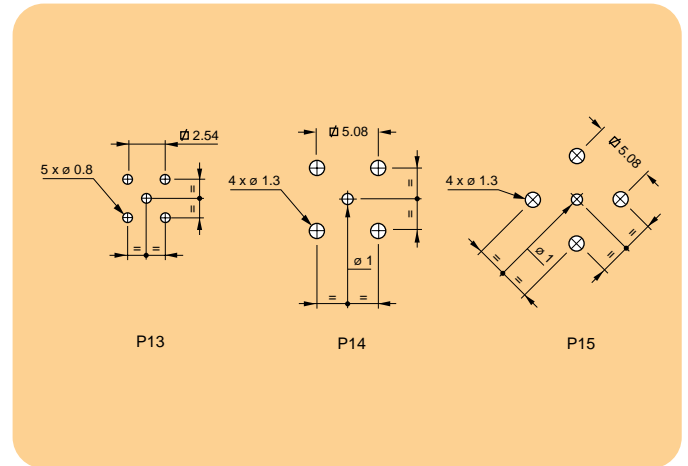

Tools / Werkzeuge

Crimping tool Crimpzange



Part Number Bestell-Nummer	Cable group Kabelgruppe	Dimensions Dimensionen (mm)	
		A	B
SAA.950.10380	1-2	0.7	3.4
SAA.950.10440	3-4	0.7	3.8
SAA.950.00440	3	-	3.8
SAA.950.10530	5-6	0.7	4.7
SAA.950.10630	7	0.7	5.5
SAA.950.10620	8	0.7	5.4
SAA.950.13700	9	1.0	6.2

Spanner Spannschlüssel

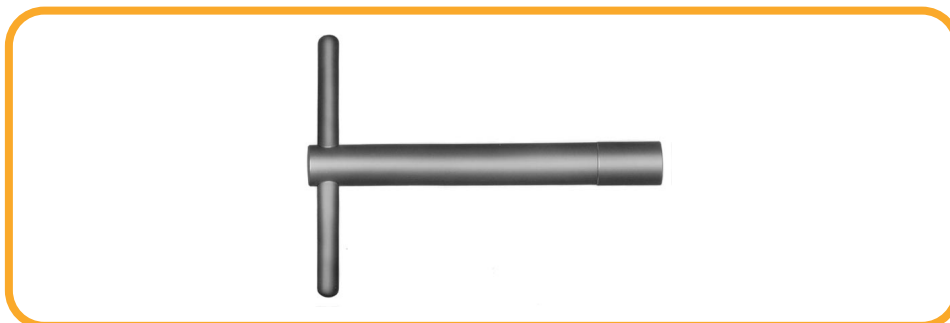

Part Number Bestell-Nummer
SAA.960.1656

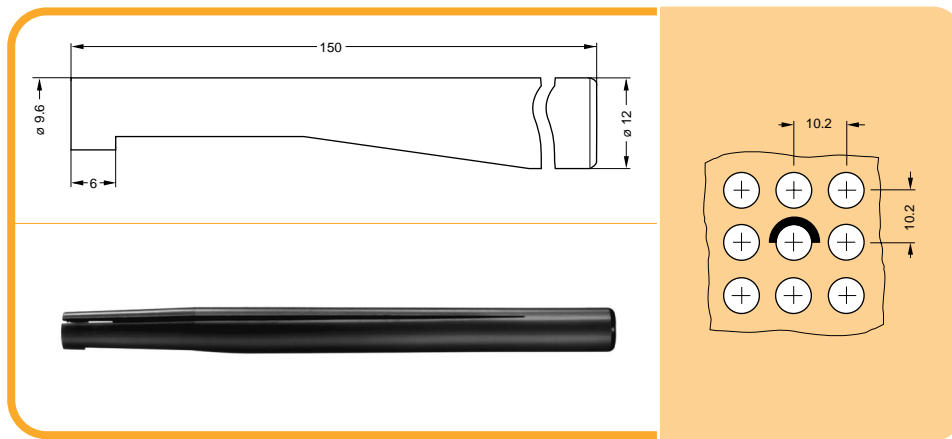
**Extractor
Ausstoßwerkzeug**

Part No. / Best-Num.: SAA.960.0075

This type of tool has been produced in order to facilitate the mating and unmating of push-pull self-latching plugs and is particularly useful in high density applications.

Dieser Typ von Werkzeug wurde produziert, um die Einführung und die Extraktion von Stecker mit Push-Pull selbstverriegelnden Verbindung zu erleichtern, für den Gebrauch bei hoher Packungsdichte.

Material: anodized aluminium
Material: eloxiertes Aluminium

Coaxial connectors (50 Ω) Koaxiale Steckverbinder (50 Ω)

SBA Series

This coaxial 1.0/2.3 series complies with the DIN 41 626 2nd part standard, with clip fixing on male connectors, mixed type, according to the DIN 41 612 Type M standard.

SBA Serie

Die Koaxial-Steckverbinder Serie 1.0/2.3 entspricht der Norm DIN 41 626 Absatz 2, mit Clipsbefestigung auf dem weiblichen Kontakteil gemäß Norm DIN 41 612, Typ M.

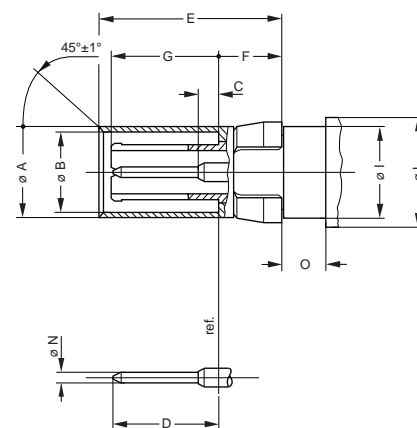
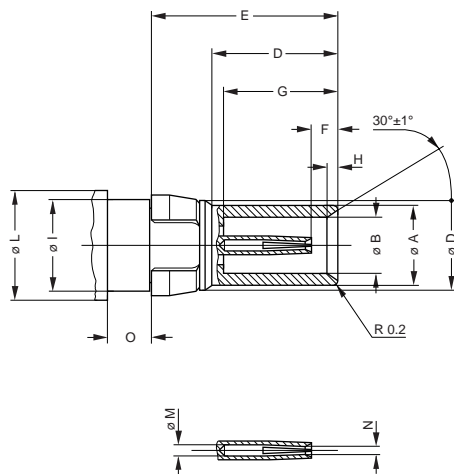

Socket / Apparatedose

LTR	Dimensions / Dimensionen (mm)	
	min.	max.
A	4.03	4.15
B	3.00	3.06
D	6.40	6.50
E	9.50	9.60
F	1.15	1.45
G	5.80	5.90
H	0.50	0.60
I	4.76	4.79
L	-	6.00
M	0.55	-
N	¹⁾	-
O	2.22	2.40

1) Appropriate dimensions to meet the mating and unmating forces as shown in the 'Mechanical Characteristics' table.

Plug / Stecker

LTR	Dimensions / Dimensionen (mm)	
	min.	max.
A	4.66	4.72
B	4.20	4.27
C	-	1.15
D	5.20	5.50
E	9.25	9.35
F	3.05	3.20
G	5.40	5.70
I	4.76	4.79
L	-	6.00
N	0.48	0.52
O	2.22	2.40

1) Dimensionen zur Einhaltung der Angaben der Verriegelungs- und Entriegelungskräfte in der Tabelle der 'Mechanische Eigenschaften'.

Construction examples

Konstruktionsbeispiele

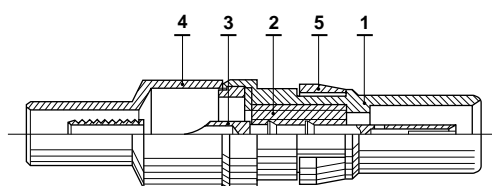

Straight socket for crimping
Gerade Dose zum Crimpen

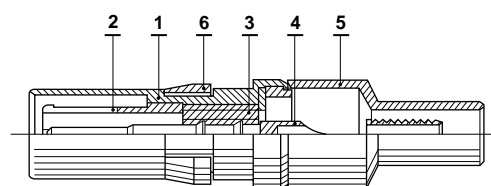

Straight plug for crimping
Gerader Stecker zum Crimpen

Characteristics / Eigenschaften

Construction examples

STRAIGHT SOCKET FOR CRIMPING

Part	Material (standard)	Treatment
1 Outer shell	Brass (UNS C 38500)	(Cu+Ni) 2.5µm+Au 1µm ¹⁾
2 Insulator	PTFE (ASTM D 1457-83)	
3 Female contact	Cu-Be (QQ-C-530)	(Cu+Ni) 2.5µm+Au 1.5µm
4 Crimp ferrule	Copper (UNS C 18700)	(Cu+Ni) 2.5µm
5 Retaining clip	Cu-Be (QQ-C-530)	(Cu+Ni) 2.5µm

STRAIGHT PLUG FOR CRIMPING

Part	Material (standard)	Treatment
1 Outer shell	Brass (UNS C 38500)	(Cu+Ni) 2.5µm+Au 1µm
2 Earthing contact	Cu-Be (QQ-C-530)	(Cu+Ni) 2.5µm+Au 1µm
3 Insulator	PTFE (ASTM D 1457-83)	
4 Male contact	Brass (UNS C 38500)	(Cu+Ni) 2.5µm+Au 1µm
5 Crimp ferrule	Copper (UNS C 18700)	(Cu+Ni) 2.5µm
6 Retaining clip	Cu-Be (QQ-C-530)	(Cu+Ni) 2.5µm

1) Housing has a general surface treatment of Au=0.5µm and the contact has a treatment of Au=1µm.

Konstruktionsbeispiele

GERADE DOSE ZUM CRIMPEN

Bestandteile	Material (Norm)	Behandlung
1 Außenkörper	Messing (UNS C 38500)	(Cu+Ni) 2.5µm+Au 1µm ¹⁾
2 Isolationsteil	PTFE (ASTM D 1457-83)	
3 Buchsenkontakt	Cu-Be (QQ-C-530)	(Cu+Ni) 2.5µm+Au 1.5µm
4 Crimphülse	Kupfer (UNS C 18700)	(Cu+Ni) 2.5µm
5 Festhalteclips	Cu-Be (QQ-C-530)	(Cu+Ni) 2.5µm

GERADER STECKER ZUM CRIMPEN

Bestandteile	Material (Norm)	Behandlung
1 Außenkörper	Messing (UNS C 38500)	(Cu+Ni) 2.5µm+Au 1µm
2 Massekontakt	Cu-Be (QQ-C-530)	(Cu+Ni) 2.5µm+Au 1µm
3 Isolationsteil	PTFE (ASTM D 1457-83)	
4 Stiftkontakt	Messing (UNS C 38500)	(Cu+Ni) 2.5µm+Au 1µm
5 Crimphülse	Kupfer (UNS C 18700)	(Cu+Ni) 2.5µm
6 Festhalteclips	Cu-Be (QQ-C-530)	(Cu+Ni) 2.5µm

1) Der Körper hat eine Oberflächenbehandlung von Au=0.5µm und der Kontaktpunkt hat eine Oberflächenbehandlung von Au=1µm.

Voltage standing wave ratio (VSWR) Stehwellenverhältnis

Plug model 185 and socket model 326, Gerader Stecker Modell 185 und gerade Apparatedose Modell 326, RG.316/U cable (50 Ω)
VSWR = 1.03 + 0.26 f (GHz)

RG.316/U Kabel (50 Ω)
VSWR = 1.03 + 0.26 f (GHz)

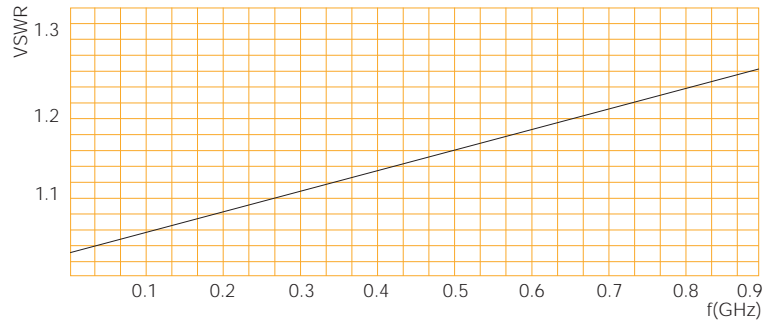

Electrical and Climatrical Characteristics

Characteristics	Value
Nominal impedance	50 Ω
Max. operating frequency	0.65 GHz
VSWR	≤ 1.2
Testing voltage	750 V rms. (50 Hz)
Operating voltage	250 V rms. (50 Hz)
Insulation resistance	≥ 1000 MΩ
Contact resistance	≤ 10 mΩ
Outer contact resistance	≤ 3 mΩ
Rated current	0.5 A
Operating temperature	-50°C + 155°C

Mechanical Characteristics

Characteristics	Value
Mating force	≤ 10 N ²⁾
Unmating force	≤ 10 N ²⁾
Mechanical endurance	> 500 cycles

Cable group Kabelgruppe		Standard Norm			Imp. (Ω)
1	2	MIL-C-17	96 IEC	CCTU10-01A	
●		RG.174 A/U	50-2-1	KX3B	50
	●	RG.178 A/U	50-1-1	KX21A	50
●	●	RG.179 B/U	75-2-1		75
●		RG.187 A/U	75-2-2		75
●		RG.188 A/U	50-2-3		50
	●	RG.196 A/U	50-1-2		50
●		RG.316 /U	50-2-2	KX22A	50

Elektrische und Klimatische Eigenschaften

Eigenschaften	Werte
Nominale Impedanz	50 Ω
Max. Betriebsfrequenz	0.65 GHz
VSWR	≤ 1.2
Prüfspannung	750 V eff. (50 Hz)
Betriebsspannung	250 V eff. (50 Hz)
Isolationswiderstand	≥ 1000 MΩ
Kontaktwiderstand	≤ 10 mΩ
Außenkontaktwiderstand	≤ 3 mΩ
Nennstrom	0.5 A
Umgebungstemperatur	-50°C + 155°C

Mechanische Eigenschaften

Eigenschaften	Werte
Verriegelungskraft	≤ 10 N ²⁾
Entriegelungskraft	≤ 10 N ²⁾
Mechanische Lebensdauer	> 500 Zyklen

2) The IEC 60512-7 standard test 13a, applies only to mating and unmating force measurements.
2) Die IEC 60512-7 Norm test 13a ist nur für Verriegelungskraft und Entriegelungskraft Abmessungen verwendbar.

On request these connectors can be adapted to suit other types of coaxial cables, not shown in the adjacent table, without changing their technical characteristics.

Auf Verlangen ist es möglich, diese Serie an andere Typen von Koaxkabeln anzupassen, die nicht in der beigefügten Tabelle vorgestellt sind, ohne daß Veränderungen in ihren technischen Eigenschaften erfolgen.

Model / Modell

Straight plug for soldering onto printed circuit Gerader Stecker zum Löten auf gedruckter Schaltung

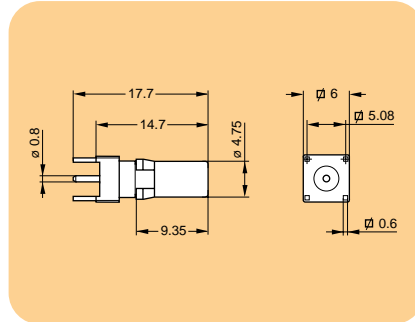
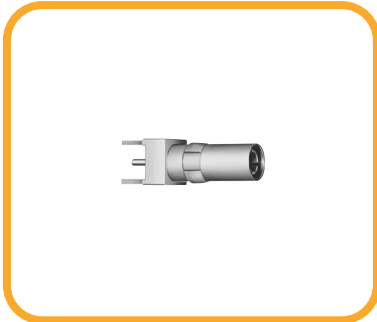

Elbow plug (90°) for soldering onto printed circuit Winkelstecker (90°) zum Löten auf gedruckter Schaltung

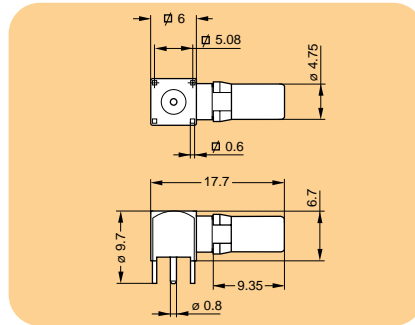
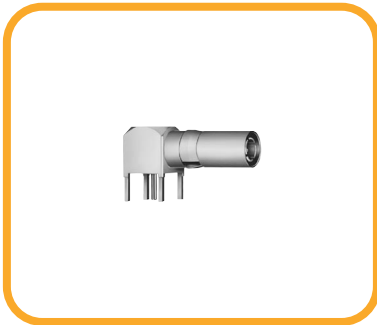

Straight plug for crimping Gerader Stecker zum Crimpen

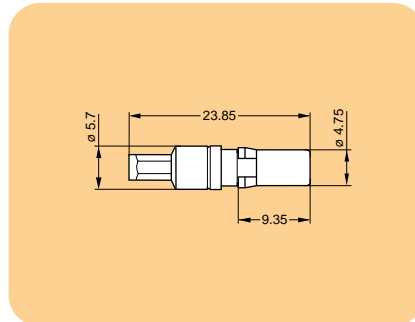
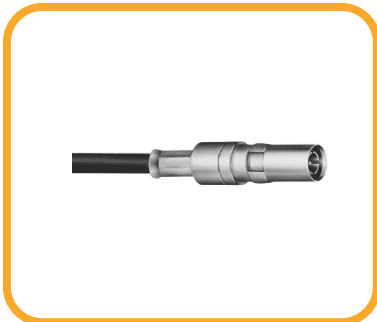

Elbow plug (90°) for crimping Winkelstecker (90°) zum Crimpen

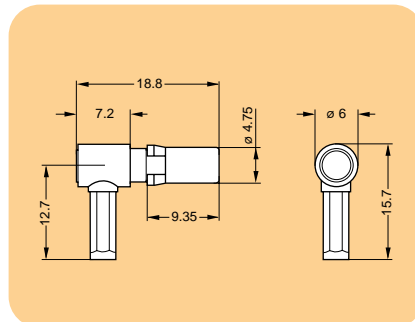

Part Number Bestell-Nummer	Cable group Kabelgruppe	Housing finish Körperbehandlung	Cable assembly Kabelmontage	Panel hole or printed circuit Bohrung der Frontpl. oder g. S.
SBA.130.50.10000 SBA.130.50.20000	- -	Au Ni	- -	P1 P1
SBA.138.50.10600 SBA.138.50.20600	- -	Au Ni	- -	P1 P1
SBA.185.50.10021 SBA.185.50.10028 SBA.185.50.20021 SBA.185.50.20028	1 2 1 2	Au Au Ni Ni	M1 M1 M1 M1	- - - -
SBA.194.50.10021 SBA.194.50.10028 SBA.194.50.20021 SBA.194.50.20028	1 2 1 2	Au Au Ni Ni	M2 M2 M2 M2	- - - -

Model / Modell

Elbow plug (90°) for crimping Winkelstecker (90°) zum Crimpen

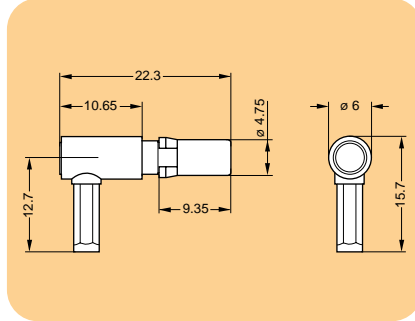

Elbow plug (90°) for crimping Winkelstecker (90°) zum Crimpen

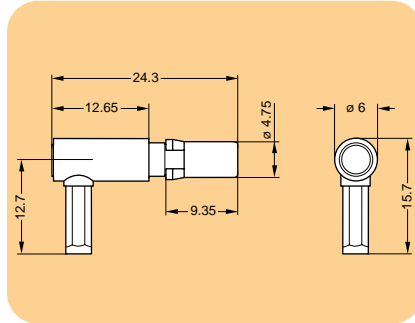

Fixed socket for soldering onto printed circuit Gerade Apparatedose zum Lötten auf gedruckter Schaltung

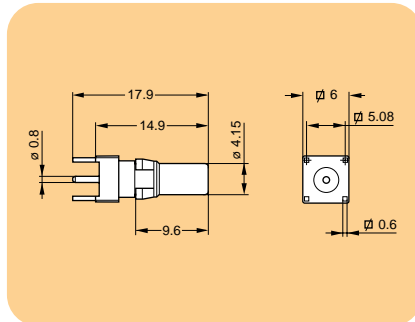
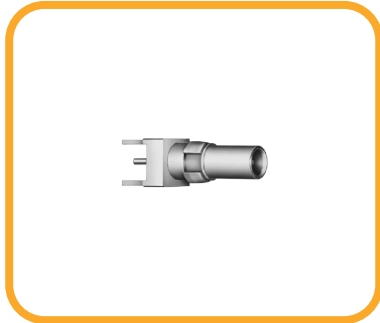

Elbow socket (90°) for soldering onto printed circuit Winkeldose (90°) zum Lötten auf gedruckter Schaltung

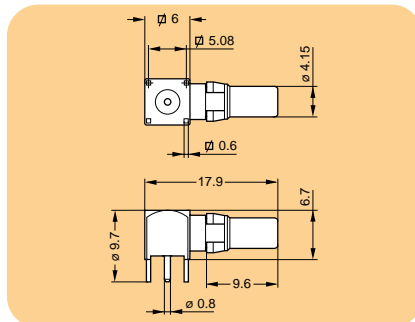
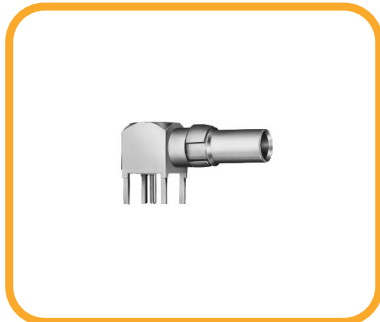

Part Number Bestell-Nummer	Cable group Kabelgruppe	Housing finish Körperbehandlung	Cable assembly Kabelmontage	Panel hole or printed circuit Bohrung der Frontpl. oder g. S.
SBA.195.50.10021	1	Au	M2	-
SBA.195.50.10028	2	Au	M2	-
SBA.195.50.20021	1	Ni	M2	-
SBA.195.50.20028	2	Ni	M2	-
SBA.196.50.10021	1	Au	M2	-
SBA.196.50.10028	2	Au	M2	-
SBA.196.50.20021	1	Ni	M2	-
SBA.196.50.20028	2	Ni	M2	-
SBA.360.50.10600	-	Au	-	P1
SBA.360.50.20600	-	Ni	-	P1
SBA.366.50.10600	-	Au	-	P1
SBA.366.50.20600	-	Ni	-	P1

Model / Modell

Straight socket for crimping Gerade Apparatedose zum Crimpen

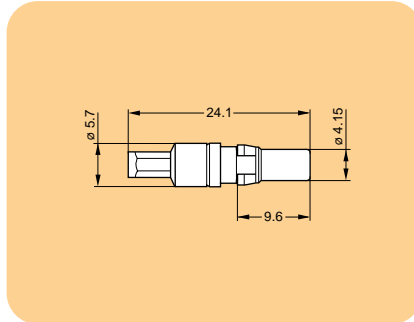
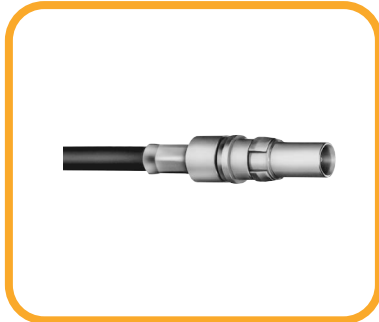

Elbow socket (90°) for crimping Winkeldose (90°) zum Crimpen

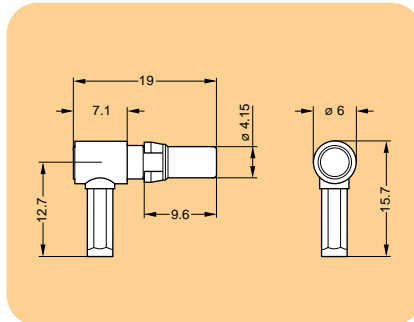
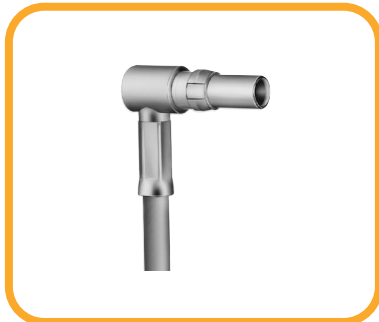

Straight socket for crimping and soldering onto printed circuit Gerade Dose zum Crimpen und zum Lötén auf gedruckter Schaltung

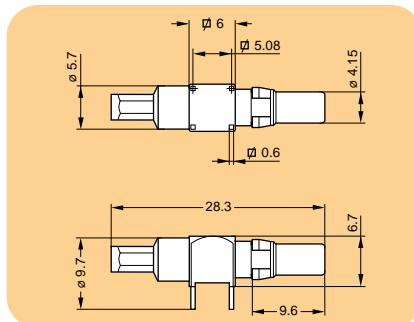
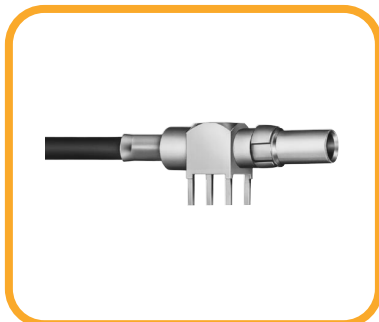

Part Number Bestell-Nummer	Cable group Kabelgruppe	Housing finish Körperbehandlung	Cable assembly Kabelmontage	Panel hole or printed circuit Bohrung der Frontpl. oder g. S.
SBA.326.50.10621	1	Au	M1	-
SBA.326.50.10628	2	Au	M1	-
SBA.326.50.20621	1	Ni	M1	-
SBA.326.50.20628	2	Ni	M1	-
SBA.311.50.10621	1	Au	M2	-
SBA.311.50.10628	2	Au	M2	-
SBA.311.50.20621	1	Ni	M2	-
SBA.311.50.20628	2	Ni	M2	-
SBA.329.50.10621	1	Au	M1	P2
SBA.329.50.10628	2	Au	M1	P2
SBA.329.50.20621	1	Ni	M1	P2
SBA.329.50.20628	2	Ni	M1	P2

M: Cable assembly / Kabelmontage

Straight connectors for crimping

Gerade Stecker zum Crimpen

- 1** Strip cable to dimensions shown in adjacent table. Slide crimp ferrule ① onto cable.

Kabel gemäß den Angaben der nachstehenden Tabelle abisolieren. Kabel in die Crimphülse ① einführen.

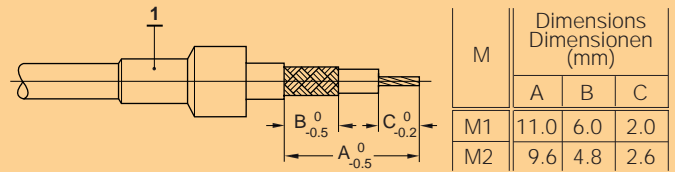

- 2** Expand screen, push cable into housing ②, fit conductor into contact and tin solder through the slot.

Die Abschirmung ausweiten, Kabel in den Steckerkörper ② einführen, den Kabelleiter in den Kontakt einführen und durch das Fenster zinnlöten.

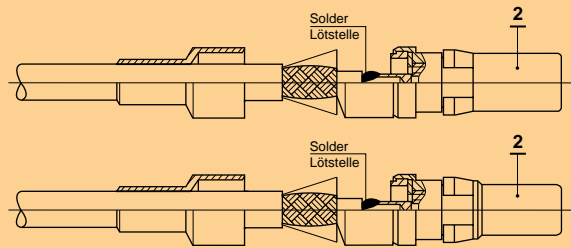

- 3** Slide crimp ferrule ① over screen until it reaches housing ②. Crimp with corresponding crimping tool.

Die Crimphülse ① über den Kabelschirm bis zum Anschlag gegen den Steckerkörper ② schieben. Mit der entsprechenden Zange crimpen.

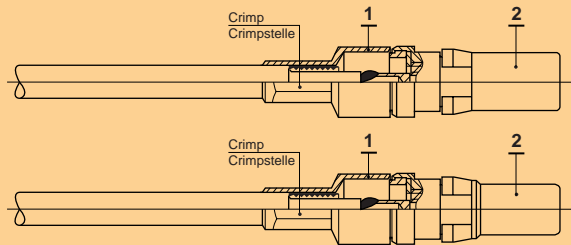

Elbow connectors for crimping

Winkelstecker zum Crimpen

- 4** After operation 1 expand screen, push cable into housing ②. Make sure conductor is correctly located in the contact slot. Tin solder through the slot. Slide crimp ferrule ① over screen until it reaches housing ②. Crimp with corresponding crimping tool. Press in blanking cap ③.

Nach der Ausführung der Anleitung 1, die Abschirmung ausweiten. Das Kabel in den Steckerkörper ② einführen. Kontrollieren, ob der Leiter richtig in die Kontaktöffnung eingeführt ist. Durch das Fenster zinnlöten. Die Crimphülse ① über den Kabelschirm bis zum Anschlag gegen den Steckerkörper schieben. Mit der entsprechenden Zange ③ crimpen. Das Loch mit der Abdeckkappe schließen.

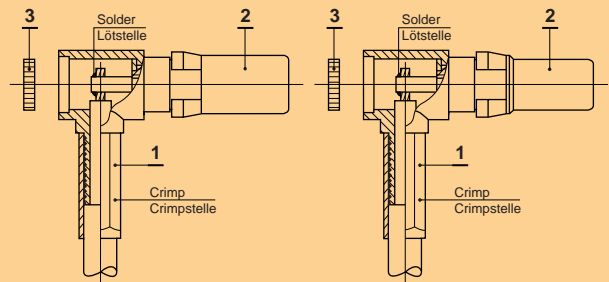

P: Drilling pattern / Bohrungsplan

Tool / Werkzeug

Printed circuit holes Bohrung der gedruckten Schaltung

Crimping tool Crimpzange

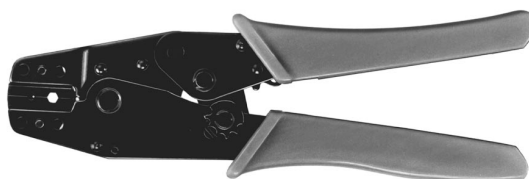
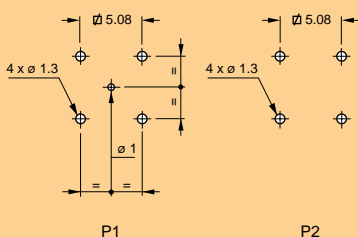

Part Number Bestell-Num.	Cable group Kabelgruppe	B (mm)
SBA.950.00300	1	2.67
SBA.950.00370	2	3.25

Coaxial Connectors (75 Ω) DIN 47 295 and CECC 22240

Koaxial - Steckverbinder (75 Ω) DIN 47 295 und CECC 22240

TAA Series

This series of 1.6/5.6 coaxial connectors, according to the DIN 47 295 and CECC 22240 standards, was designed to meet the requirements of high performance high reliability telephone transmission and communication techniques.

The 1.6/5.6 connector series provides 4 types of coupling depending on their use: A form screw type, B form spring type, C form free type and F form Push-Pull self-latching type offering absolute security against vibrations and accidental pull on the cable.

TAA Serie

Die Koaxial-Steckverbindung, Serie 1.6/5.6, entspricht der Norm DIN 47 295 und CECC 22240. Sie wurde für Anwendungen mit hoher Leistungsfähigkeit und Zuverlässigkeit im Bereich Übertragungstechnik und telefonische Leitungszüge geschaffen.

Die Serie 1.6/5.6 ermöglicht vier Verriegelungsarten: A Version mit Schraubverriegelung, B Version mit Federverriegelung, C Version mit loser Verriegelung und F Version mit dem Push-Pull Selbstverriegelungssystem. Mit dem Push-Pull System ist eine absolute Sicherheit gegen Vibration, sowie durch zufälliges Ziehen auf das Kabel garantiert.

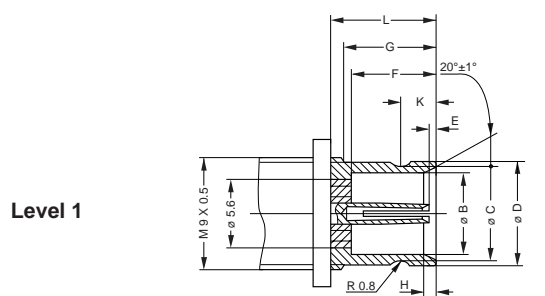

Level 1

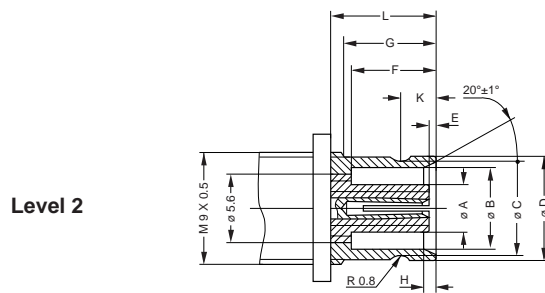

Level 2

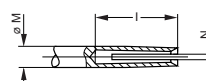

Socket / Apparatedose

LTR	Dimensions / Dimensionen (mm)	
	min.	max.
A	–	3.80
B	6.60	6.69
C	7.20	7.45
D	8.10	8.25
E	0.25	0.75
F	6.70	–
G	7.00	7.50
H	0.90	1.10
I	6.50	–
K	3.10	2.90
L	9.70	–
M	1.59	1.61
N	1)	–

Dimensions for connectors in general use according to CECC 22240.

1) Dimensions to meet the mating and unmating forces given under «Mechanical Characteristics». Complies with the gauging test of the DIN 47 295 standard.

2) For test connectors.

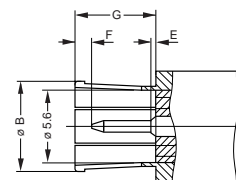

Stand 1

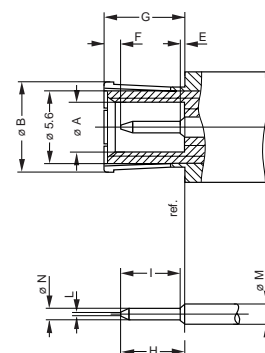

Stand 2

Plug / Stecker

LTR	Dimensions / Dimensionen (mm)	
	min.	max.
A	4.00	–
B	1)	–
E	–	0.15
F	0.75	1.45
G	6.40	6.60
H	–	5.50
I	5.40 ²⁾	5.50 ²⁾
L	–	0.10
M	1.59	1.61
N	0.97	1.03

Dimensionen für allgemeine verwendete Steckverbinder gemäss CECC 22240.

1) Dimensionen zur Einhaltung der Angaben der Verriegelungs- und Entriegelungskräfte in der Tabelle der «Mechanische Eigenschaften». Gemäss Eichungsprüfung der Norm DIN 47 295.

2) Für Meßsteckverbinder.

Coupling types / Verbindung Modelle

A Form A Version

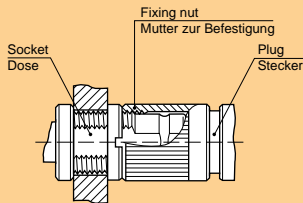

With this type of coupling the plug is easily screwed to the socket by means of the plug's threaded nut.

Mit dieser Verbindung kann der Stecker mit Hilfe von einer auf dem Stecker befestigten Mutter ohne Spannung auf die Dose geschraubt werden.

B Form B Version

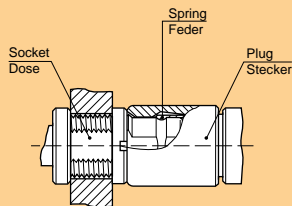

This type of coupling between a plug and a socket is made possible by a sleeve fitted with a spring in the plug, which enables the fixing of the two connectors.

Die Verbindung zwischen Stecker und Dose wird durch eine Hülse ermöglicht, welche über eine Feder ausgerüstet wurde. Hierdurch wird die Verbindung zwischen Buchse und Stecker hergestellt.

C Form C Version

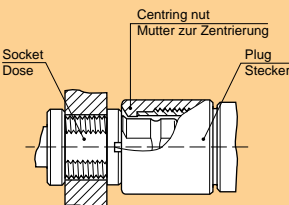

This type of free coupling between a plug and a socket is made possible by a conical guide screwed onto the plug which provides a perfect centering between the two connectors.

Bei der frei steckbaren Type wird die Zentrierung zwischen den beiden Steckern durch den Eingangskonus ermöglicht, mit welchem der Stecker ausgerüstet ist.

F form self-latching connection F Version Push-Pull selbstverriegelnde Verbindung

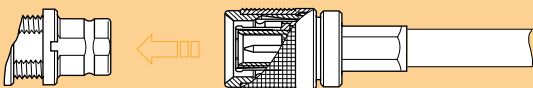

This new type of patented self-latching coupling provides a simple and quick mating between a plug and a socket. It is guaranteed against vibration and accidental pull on the cable.

Die neu patentierte Verriegelung erlaubt eine einfache und schnelle Kupplung zwischen Stecker und Dose und ist gegen alle Vibrationen und zufällige Zugkräfte auf das Kabel gesichert.

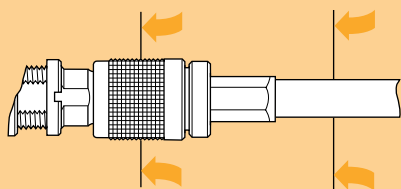

1 A plug and a socket are mated by a simple axial push on the outer shell of the plug or the cable.

Die Verriegelung zwischen Stecker und Dose wird durch einen einfachen axialen Schub über den Außenkörper des Steckers, oder des Kabels erreicht.

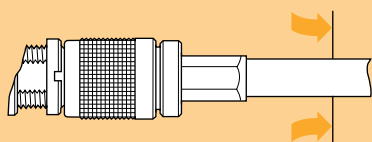

2 A pull on the cable or any part of the plug, other than the external release sleeve, will not release the latch.

Die Verbindung läßt sich nur durch Ziehen am Außenkörper lösen. Durch Ziehen am Kabel oder einem anderen Teil des Steckers ist eine Entriegelung nicht möglich.

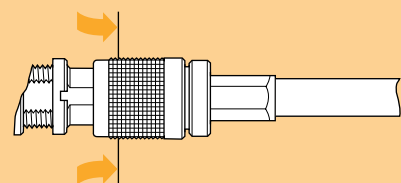

3 To unlatch a plug from a socket, an axial pull must be exerted on the external release sleeve of the plug.

Um den Stecker von der Dose zu entriegeln, muß ein axialer Zug auf den Außenkörper des Steckers ausgeübt werden.

Characteristics / Eigenschaften

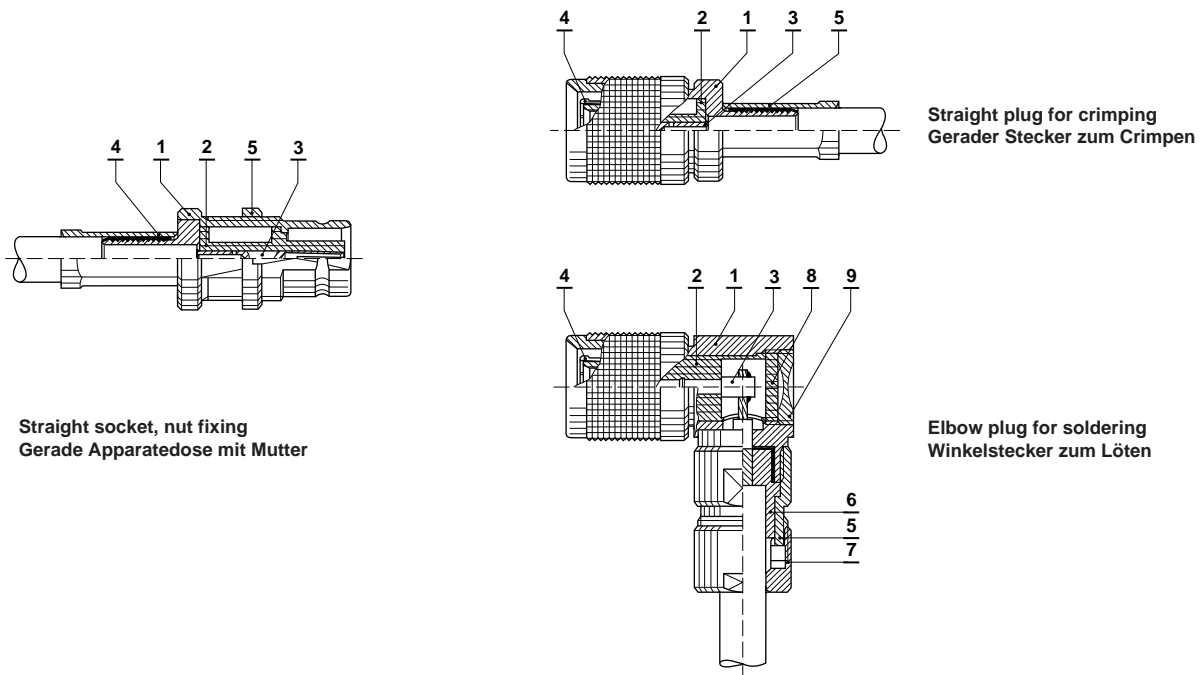

Examples of Construction

STRAIGHT SOCKET FOR CRIMPING

Part	Material (standard)	Treatment
1 Housing	Brass (UNS C 38500)	(Cu+Ni) 2.5µm+Au 1µm ¹⁾
2 Insulator	PTFE (ASTM D 1457-83)	
3 Female contact	Cu-Be (QQ-C-530)	(Cu+Ni) 2.5µm+Au 1.5µm
4 Crimp ferrule	Copper (UNS C 18700)	(Cu+Ni) 2.5µm
5 Fixing nut	Brass (UNS C 38500)	(Cu+Ni) 2.5µm

STRAIGHT PLUG FOR CRIMPING

Part	Material (standard)	Treatment
1 Housing	Brass (UNS C 38500)	Cu 0.3µm+Ni 5µm
2 Insulator	PTFE (ASTM D 1457-83)	
3 Male contact	Brass (UNS C 34500)	(Cu+Ni) 2.5µm+Au 1µm
4 Earthing contact	Cu-Be (QQ-C-530)	(Cu+Ni) 2.5µm+Au 1µm
5 Crimp ferrule	Copper (UNS C 18700)	(Cu+Ni) 2.5µm

ELBOW PLUG FOR SOLDERING

Part	Material (standard)	Treatment
1 Housing	Brass (UNS C 38500)	Cu 0.3µm+Ni 5µm
2 Insulator	PTFE (ASTM D 1457-83)	
3 Male contact	Brass (UNS C 38500)	(Cu+Ni) 2.5µm+Au 1µm
4 Earthing contact	Cu-Be (QQ-C-530)	(Cu+Ni) 2.5µm+Au 1µm
5 Retaining ring	Brass (UNS C 38500)	Cu 0.3µm+Ni 2.5µm
6 Collet	Brass (UNS C 38500)	Cu 0.3µm+Ni 2.5µm
7 Collet nut	Brass (UNS C 38500)	Cu 0.3µm+Ni 2.5µm
8 Insulating washer	PTFE (ASTM D 1457-83)	
9 Screw	Brass (UNS C 38500)	Cu 0.3µm+Ni 2.5µm

1) The socket housing has a general surface treatment of Au=0.5µm and the contact has a treatment of Au=1µm.

Konstruktionsbeispiele

GERADE APPARATEDOSE ZUM CRIMPEN

Bestandteile	Material (Norm)	Behandlung
1 Außenkörper	Messing (UNS C 38500)	(Cu+Ni) 2.5µm+Au 1µm ¹⁾
2 Isolationsteil	PTFE (ASTM D 1457-83)	
3 Buchsenkontakt	Cu-Be (QQ-C-530)	(Cu+Ni) 2.5µm+Au 1.5µm
4 Crimphülse	Kupfer (UNS C 18700)	(Cu+Ni) 2.5µm
5 Befestigungsmutter	Messing (UNS C 38500)	(Cu+Ni) 2.5µm

GERADER STECKER ZUM CRIMPEN

Bestandteile	Material (Norm)	Behandlung
1 Außenkörper	Messing (UNS C 38500)	Cu 0.3µm+Ni 5µm
2 Isolationsteil	PTFE (ASTM D 1457-83)	
3 Stiftkontakt	Messing (UNS C 34500)	(Cu+Ni) 2.5µm+Au 1µm
4 Massekontakt	Cu-Be (QQ-C-530)	(Cu+Ni) 2.5µm+Au 1µm
5 Crimphülse	Kupfer (UNS C 18700)	(Cu+Ni) 2.5µm

WINKELSTECKER ZUM LÖTEN

Bestandteile	Material (Norm)	Behandlung
1 Außenkörper	Messing (UNS C 38500)	Cu 0.3µm+Ni 5µm
2 Isolationsteil	PTFE (ASTM D 1457-83)	
3 Stiftkontakt	Messing (UNS C 38500)	(Cu+Ni) 2.5µm+Au 1µm
4 Massekontakt	Cu-Be (QQ-C-530)	(Cu+Ni) 2.5µm+Au 1µm
5 Festhaltering	Messing (UNS C 38500)	Cu 0.3µm+Ni 2.5µm
6 Spannzange	Messing (UNS C 38500)	Cu 0.3µm+Ni 2.5µm
7 Spannschraube	Messing (UNS C 38500)	Cu 0.3µm+Ni 2.5µm
8 Isolierscheibe	PTFE (ASTM D 1457-83)	
9 Schraube	Messing (UNS C 38500)	Cu 0.3µm+Ni 2.5µm

1) Der Körper der Apparatedose hat eine Oberflächenbehandlung von Au=0.5µm und der Kontaktpunkt hat eine Oberflächenbehandlung von Au=1µm.

Characteristics / Eigenschaften

Voltage standing wave ratio (VSWR) Stehwellenverhältnis

Test conditions:

Straight plug for crimping, model 189 and straight socket for crimping, model 324, 2YCY cable (0.4/2.5) (75 Ω)
VSWR: 1.06 + 1 f (GHz)

Prüfbedingungen:

Gerader Stecker zum Crimpen, Modell 189 und gerade Apparatedose zum Crimpen, Modell 324, 2YCY (0.4/2.5) Kabel (75 Ω)
VSWR: 1.06 + 1 f (GHz)

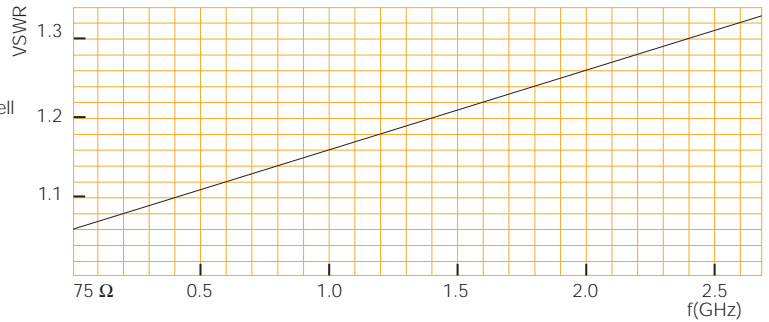

Electrical and Climatrical Characteristics

Characteristics	Value
Nominal impedance	75 Ω
Max. operating frequency	1.4 GHz
VSWR	≤ 1.2
Testing voltage	750 V rms. (50 Hz)
Operating voltage	250 V rms. (50 Hz)
Insulation resistance	≥ 10 ⁹ MΩ (at 500 Vdc)
Contact resistance	≤ 1.6 mΩ
Outer contact resistance	≤ 1.4 mΩ
Rated current	6 A
Operating temperature	-55°C +250°C

Mechanical Characteristics

Characteristics	Value
(C Form)	
Mating force	≤ 6 N ¹⁾
Unmating force	≤ 5 N ¹⁾
Mechanical endurance	> 500 cycles
(Push-Pull self-latching)	
Mating force	≤ 10 N ¹⁾
Unmating force	≤ 7.5 N ¹⁾
Latch retention force	≥ 450 N
Mechanical endurance	> 500 cycles

Elektrische und Klimatische Eigenschaften

Eigenschaften	Werte
Nominale Impedanz	75 Ω
Max. Betriebsfrequenz	1.4 GHz
VSWR	≤ 1.2
Prüfspannung	750 V eff. (50 Hz)
Betriebsspannung	250 V eff. (50 Hz)
Isolationswiderstand	≥ 10 ⁹ MΩ (bei 500 Vdc)
Kontaktwiderstand	≤ 1.6 mΩ
Außenkontaktwiderstand	≤ 1.4 mΩ
Nennstrom	6 A
Umgebungstemperatur	-55°C +250°C

Mechanische Eigenschaften

Eigenschaften	Werte
(C Version)	
Verriegelungskraft	≤ 6 N ¹⁾
Entriegelungskraft	≤ 5 N ¹⁾
Mechanische Lebensdauer	> 500 Zyklen
(Push-Pull selbstverriegelnde Verbindung)	
Verriegelungskraft	≤ 10 N ¹⁾
Entriegelungskraft	≤ 7.5 N ¹⁾
Zurückbehaltungskraft	≥ 450 N
Mechanische Lebensdauer	> 500 Zyklen

Cable group Kabelgruppe	Standard Norm				Imp. (Ω)
	1	2	3	4	
	MIL-C-17	96 IEC	CCTU10-01A	Other/Andere	
	RG.59 B/U	75-4-1			75
	RG.179 B/U	75-2-1			75
	RG.187 A/U	75-2-2			75
	RG.188 A/U	50-2-3			50
	RG.316 /U	50-2-2	KX22A		50
				02Y(ST)CY(0.45/2.0)	75
				2YCY(0.4/2.5)	Siemens 75
				2YCCY (0.4/2.5)	Siemens 75
				5YC(ms)C6Y45/1.9-75vsws	Gore 75
				ST.121	FMC 75
				Thin coax	Alcatel 75
				ST.212 (0.4/2.0) R	FMC 75
				ST.214	FMC 75
				L910/39	75
				8241	Belden 75
				YR 23769	Belden 75

1) The IEC 60512-7 standard test 13a applies only to mating and unmating force measurements.

1) Die IEC 60512-7 Norm test 13a ist nur für Verriegelungskraft und Entriegelungskraft Abmessungen verwendbar.

On request these connectors can be adapted to suit other types of coaxial cables, not shown in the adjacent table, without changing their technical characteristics.

Auf Verlangen ist es möglich, diese Serie von Steckverbinder an andere Type von Koaxkabeln anzupassen, die nicht in der beigefügten Tabelle vorgestellt sind, ohne daß Veränderungen in ihren technischen Eigenschaften erfolgen.

Part number example

TAA.189.75.20128

TAA: DIN 1.6/5.6 Series

189: Model: straight plug for crimping, push-pull coupling

75: Impedance: 75 = 75 Ω

2: Housing finish: 1 = gold 2 = nickel 6 = silver

0: Insulator material: teflon PTFE

1: Type of contact:

0 = male solder contact 1 = male crimp contact

6 = female solder contact 7 = female crimp contact

28: Diameter of cable entry : 28 = 2.8 mm

Beispiel für Bestell-Nummer

TAA.189.75.20128

TAA: DIN 1.6/5.6 Serie

189: Modell: gerader Stecker zum Crimpen, push-pull Verriegelung

75: Impedanz: 75 = 75 Ω

2: Körperbehandlung: 1 = vergoldet 2 = vernickelt 6 = versilbert

0: Isolationsmaterial: teflon PTFE

1: Kontaktyp:

0 = Stiftkontakt zum Löten 1 = Stiftkontakt zum Crimpen

6 = Buchsenkontakt zum Löten 7 = Buchsenkontakt zum Crimpen

28: Durchmesser für die Kabeleinführung: 28 = 2.8 mm

Model / Modell

Straight plug with cable collet, Push-Pull self-latching coupling Gerader Stecker mit Zugentlastung, Push-Pull selbstverriegelnde Verbindung

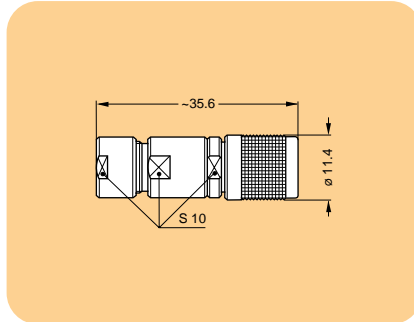

Straight plug with cable collet, screw-fixing Gerader Stecker mit Zugentlastung, Schraubverbindung

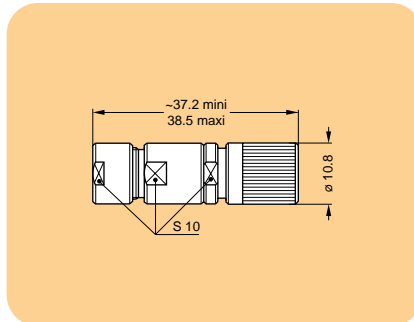

Straight plug for crimping, Push-Pull self-latching coupling Gerader Stecker zum Crimpen, Push-Pull selbstverriegelnde Verbindung

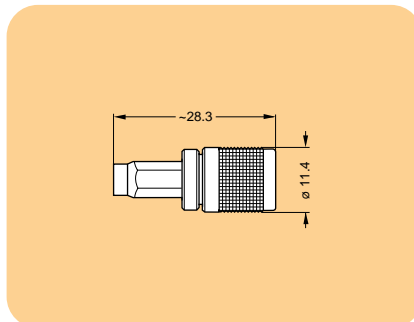
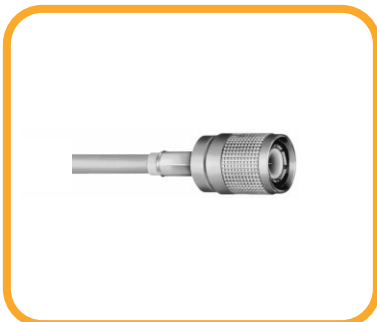

Straight plug for crimping, Push-Pull self-latching coupling Gerader Stecker zum Crimpen, Push-Pull selbstverriegelnde Verbindung

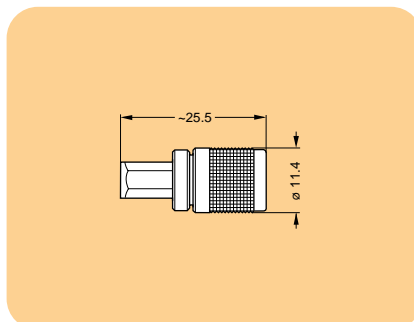

Part Number Bestell-Nummer	Cable group Kabelgruppe	Housing finish Körperbehandlung	Cable assembly Kabelmontage	Panel hole or printed circuit Bohrung der Frontpl. oder g. S.
TAA.100.75.20028	1	Ni	M1	-
TAA.100.75.20029	2	Ni	M1	-
TAA.100.75.20035	3	Ni	M1	-
TAA.100.75.20038	4	Ni	M1	-
TAA.100.75.20042	5	Ni	M1	-
TAA.100.75.20043	6	Ni	M1	-
TAA.100.75.20047	13	Ni	M1	-
TAA.100.75.20048	7	Ni	M1	-
TAA.100.75.20050	8	Ni	M1	-
TAA.100.75.20061	9	Ni	M1	-
TAA.100.75.20063	10	Ni	M1	-
TAA.100.75.20067	12	Ni	M1	-
TAA.108.75.20028	1	Ni	M1	-
TAA.108.75.20029	2	Ni	M1	-
TAA.108.75.20035	3	Ni	M1	-
TAA.108.75.20038	4	Ni	M1	-
TAA.108.75.20042	5	Ni	M1	-
TAA.108.75.20043	6	Ni	M1	-
TAA.108.75.20047	13	Ni	M1	-
TAA.108.75.20048	7	Ni	M1	-
TAA.108.75.20050	8	Ni	M1	-
TAA.108.75.20061	9	Ni	M1	-
TAA.108.75.20063	10	Ni	M1	-
TAA.108.75.20067	12	Ni	M1	-
TAA.187.75.20141	11	Ni	M5	-
TAA.189.75.20128	1	Ni	M3	-
TAA.189.75.20129	2	Ni	M3	-
TAA.189.75.20135	3	Ni	M3	-
TAA.189.75.20138	4	Ni	M3	-
TAA.189.75.20142	5	Ni	M3	-
TAA.189.75.20143	6	Ni	M3	-
TAA.189.75.20146	13	Ni	M3	-
TAA.189.75.20148	7	Ni	M3	-
TAA.189.75.20150	8	Ni	M3	-
TAA.189.75.20161	9	Ni	M3	-
TAA.189.75.20163	10	Ni	M3	-
TAA.189.75.20167	12	Ni	M3	-

Model / Modell

Straight plug for crimping, screw-fixing Gerader Stecker zum Crimpen, Schraubverbindung

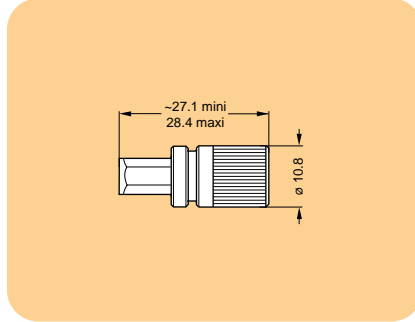
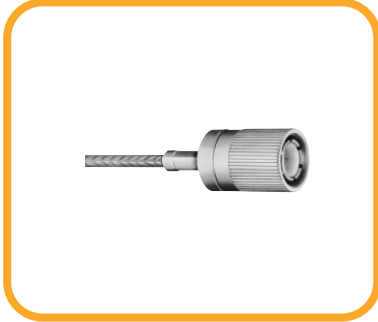

Elbow (90°) plug with cable collet, Push-Pull self-latching coupling Winkelstecker (90°) mit Zugentlastung, Push-Pull selbstverriegelnde Verbindung

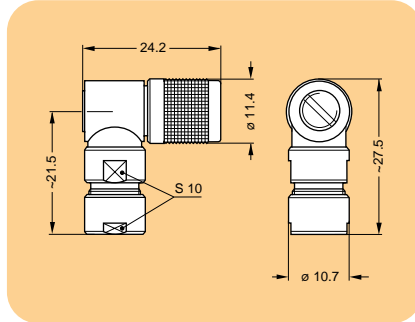

Elbow (90°) plug with cable collet, screw-fixing Winkelstecker (90°) mit Zugentlastung, Schraubverbindung

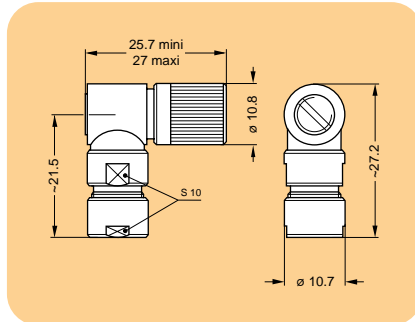

Elbow (90°) plug for crimping, Push-Pull self-latching coupling Winkelstecker (90°) zum Crimpen, Push-Pull selbstverriegelnde Verbindung

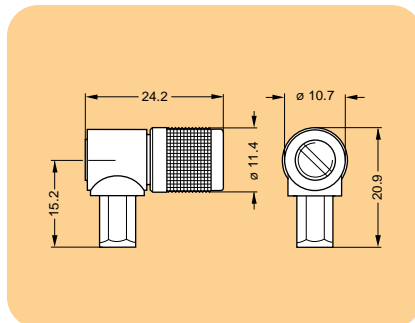

Part Number Bestell-Nummer	Cable group Kabelgruppe	Housing finish Körperbehandlung	Cable assembly Kabelmontage	Panel hole or printed circuit Bohrung der Frontpl. oder g. S.
TAA.188.75.20128	1	Ni	M3	-
TAA.188.75.20129	2	Ni	M3	-
TAA.188.75.20135	3	Ni	M3	-
TAA.188.75.20138	4	Ni	M3	-
TAA.188.75.20142	5	Ni	M3	-
TAA.188.75.20143	6	Ni	M3	-
TAA.188.75.20146	13	Ni	M3	-
TAA.188.75.20148	7	Ni	M3	-
TAA.188.75.20150	8	Ni	M3	-
TAA.188.75.20161	9	Ni	M3	-
TAA.188.75.20163	10	Ni	M3	-
TAA.188.75.20167	12	Ni	M3	-
TAA.110.75.20028	1	Ni	M2	-
TAA.110.75.20029	2	Ni	M2	-
TAA.110.75.20035	3	Ni	M2	-
TAA.110.75.20038	4	Ni	M2	-
TAA.110.75.20042	5	Ni	M2	-
TAA.110.75.20043	6	Ni	M2	-
TAA.110.75.20047	13	Ni	M2	-
TAA.110.75.20048	7	Ni	M2	-
TAA.110.75.20050	8	Ni	M2	-
TAA.110.75.20061	9	Ni	M2	-
TAA.110.75.20063	10	Ni	M2	-
TAA.110.75.20067	12	Ni	M2	-
TAA.118.75.20028	1	Ni	M2	-
TAA.118.75.20029	2	Ni	M2	-
TAA.118.75.20035	3	Ni	M2	-
TAA.118.75.20038	4	Ni	M2	-
TAA.118.75.20042	5	Ni	M2	-
TAA.118.75.20043	6	Ni	M2	-
TAA.118.75.20047	13	Ni	M2	-
TAA.118.75.20048	7	Ni	M2	-
TAA.118.75.20050	8	Ni	M2	-
TAA.118.75.20061	9	Ni	M2	-
TAA.118.75.20063	10	Ni	M2	-
TAA.118.75.20067	12	Ni	M2	-
TAA.199.75.20128	1	Ni	M4	-
TAA.199.75.20129	2	Ni	M4	-
TAA.199.75.20135	3	Ni	M4	-
TAA.199.75.20138	4	Ni	M4	-
TAA.199.75.20142	5	Ni	M4	-
TAA.199.75.20143	6	Ni	M4	-
TAA.199.75.20146	13	Ni	M4	-
TAA.199.75.20148	7	Ni	M4	-
TAA.199.75.20150	8	Ni	M4	-
TAA.199.75.20161	9	Ni	M4	-
TAA.199.75.20163	10	Ni	M4	-
TAA.199.75.20167	12	Ni	M4	-

Model / Modell

Elbow (90°) plug for crimping, screw-fixing Winkelstecker (90°) zum Crimpen, Schraubverbindung

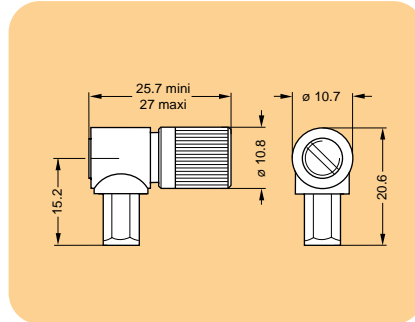

Straight socket, nut-fixing Gerade Apparatedose mit Mutter

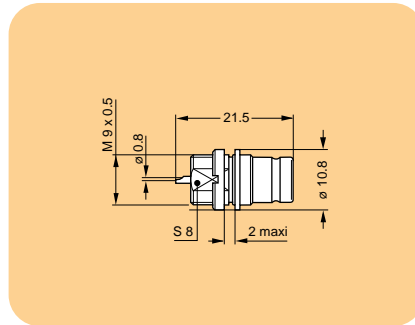
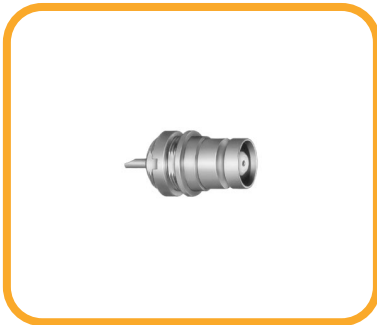

Straight socket, nut-fixing, earthing contact Gerade Apparatedose mit Mutter und Masseausgang

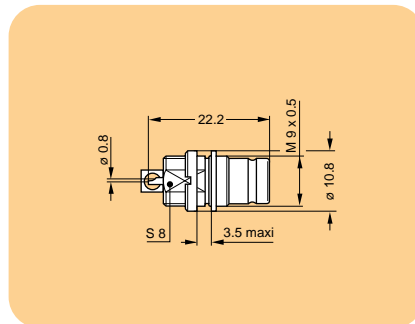
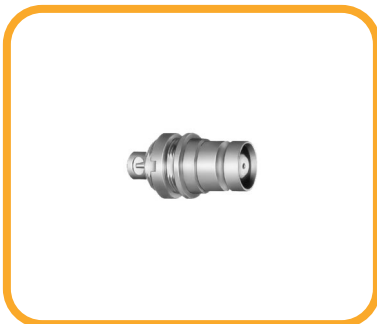

Straight socket with two nuts Gerade Apparatedose mit zwei Muttern

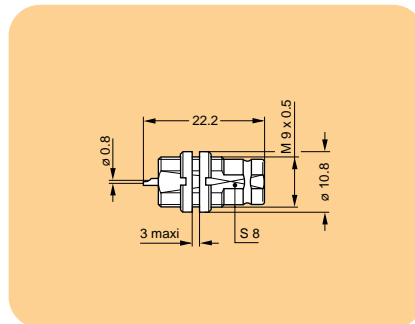
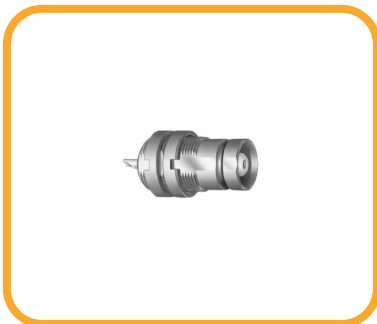

Part Number Bestell-Nummer	Cable group Kabelgruppe	Housing finish Körperbehandlung	Cable assembly Kabelmontage	Panel hole or printed circuit Bohrung der Frontpl. oder g. S.
TAA.198.75.20128	1	Ni	M4	-
TAA.198.75.20129	2	Ni	M4	-
TAA.198.75.20135	3	Ni	M4	-
TAA.198.75.20138	4	Ni	M4	-
TAA.198.75.20142	5	Ni	M4	-
TAA.198.75.20143	6	Ni	M4	-
TAA.198.75.20146	13	Ni	M4	-
TAA.198.75.20148	7	Ni	M4	-
TAA.198.75.20150	8	Ni	M4	-
TAA.198.75.20161	9	Ni	M4	-
TAA.198.75.20163	10	Ni	M4	-
TAA.198.75.20167	12	Ni	M4	-
TAA.303.75.10600	-	Au	-	P1
TAA.300.75.10600	-	Au	-	P1
TAA.305.75.10600	-	Au	-	P1

Model / Modell

Straight socket with two nuts and earthing contact Gerade Apparatedose mit zwei Muttern und Masseausgang

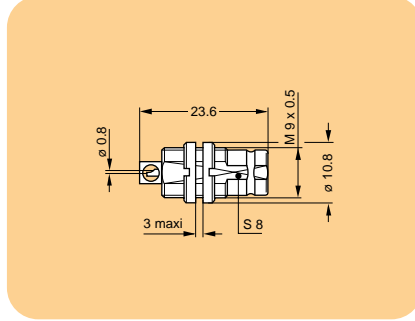
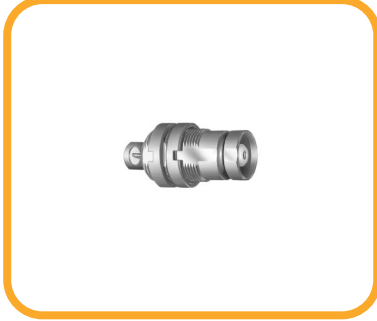

Straight socket for soldering onto printed circuit Gerade Apparatedose zum Lötén auf gedruckter Schaltung

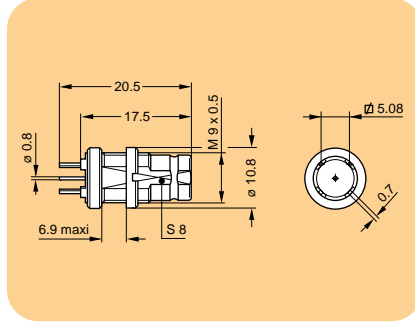
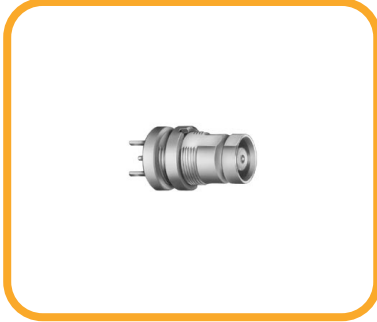

Elbow (90°) socket for printed circuit Winkeldose (90°) für gedruckte Schaltung

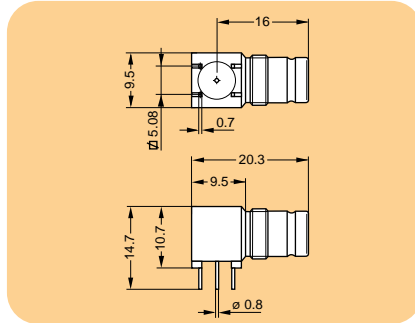
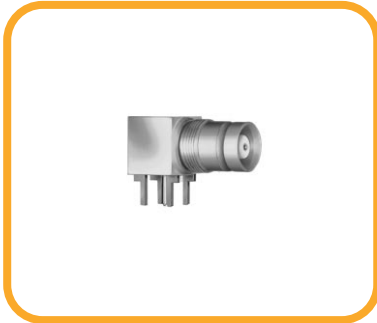

Straight socket with cable collet Gerade Apparatedose mit Zugentlastung

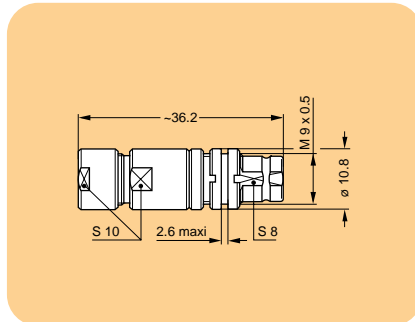
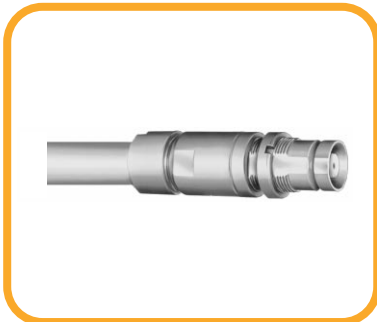

Part Number Bestell-Nummer	Cable group Kabelgruppe	Housing finish Körperbehandlung	Cable assembly Kabelmontage	Panel hole or printed circuit Bohrung der Frontpl. oder g. S.
TAA.308.75.10600	-	Au	-	P1
TAA.368.75.10600	-	Au	-	P2
TAA.367.75.10600	-	Au	-	P2
TAA.380.75.10628	1	Au	M1	P1
TAA.380.75.10629	2	Au	M1	P1
TAA.380.75.10635	3	Au	M1	P1
TAA.380.75.10638	4	Au	M1	P1
TAA.380.75.10642	5	Au	M1	P1
TAA.380.75.10643	6	Au	M1	P1
TAA.380.75.10647	13	Au	M1	P1
TAA.380.75.10648	7	Au	M1	P1
TAA.380.75.10650	8	Au	M1	P1
TAA.380.75.10661	9	Au	M1	P1
TAA.380.75.10663	10	Au	M1	P1
TAA.380.75.10667	12	Au	M1	P1

Model / Modell

Straight socket for crimping Gerade Apparatedose zum Crimpen

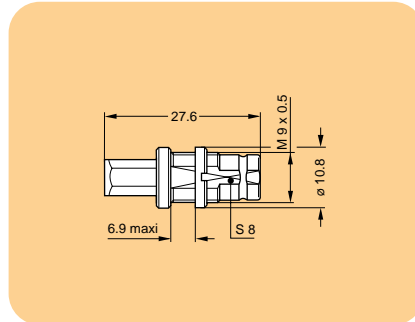
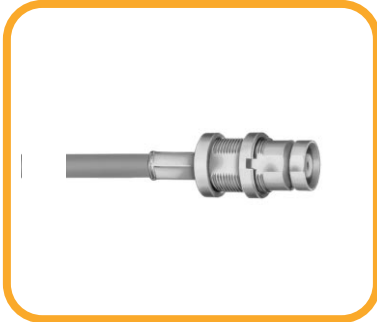

Elbow (90°) socket with cable collet Winkeldose (90°) mit Zugentlastung

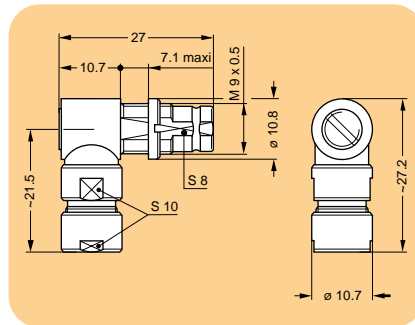

Elbow (90°) socket for crimping Winkeldose (90°) zum Crimpen

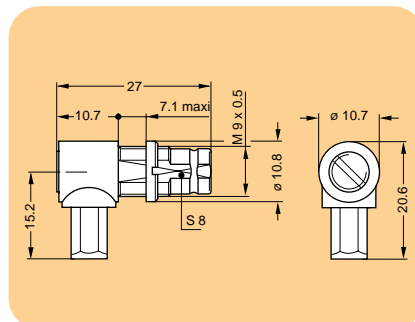

Straight plug with resistance (75 Ω) / 0.6 W, Push-Pull self-latching coupling Gerader Stecker mit Widerstand (75 Ω) / 0.6 W, Push-Pull selbstverriegelnde Verbindung

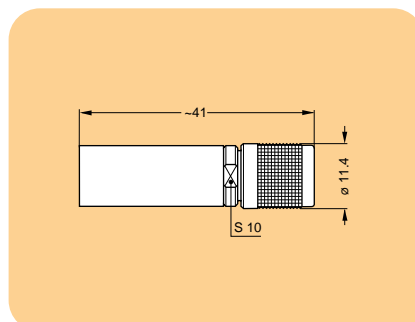

Part Number Bestell-Nummer	Cable group Kabelgruppe	Housing finish Körperbehandlung	Cable assembly Kabelmontage	Panel hole or printed circuit Bohrung der Frontpl. oder g. S.
TAA.324.75.10628	1	Au	M3	P1
TAA.324.75.10629	2	Au	M3	P1
TAA.324.75.10635	3	Au	M3	P1
TAA.324.75.10638	4	Au	M3	P1
TAA.324.75.10642	5	Au	M3	P1
TAA.324.75.10643	6	Au	M3	P1
TAA.324.75.10646	13	Au	M3	P1
TAA.324.75.10648	7	Au	M3	P1
TAA.324.75.10650	8	Au	M3	P1
TAA.324.75.10661	9	Au	M3	P1
TAA.324.75.10663	10	Au	M3	P1
TAA.324.75.10667	12	Au	M3	P1
TAA.385.75.10628	1	Au	M2	P1
TAA.385.75.10629	2	Au	M2	P1
TAA.385.75.10635	3	Au	M2	P1
TAA.385.75.10638	4	Au	M2	P1
TAA.385.75.10642	5	Au	M2	P1
TAA.385.75.10643	6	Au	M2	P1
TAA.385.75.10647	13	Au	M2	P1
TAA.385.75.10648	7	Au	M2	P1
TAA.385.75.10650	8	Au	M2	P1
TAA.385.75.10661	9	Au	M2	P1
TAA.385.75.10663	10	Au	M2	P1
TAA.385.75.10667	12	Au	M2	P1
TAA.311.75.10628	1	Au	M4	P1
TAA.311.75.10629	2	Au	M4	P1
TAA.311.75.10635	3	Au	M4	P1
TAA.311.75.10638	4	Au	M4	P1
TAA.311.75.10642	5	Au	M4	P1
TAA.311.75.10643	6	Au	M4	P1
TAA.311.75.10647	13	Au	M4	P1
TAA.311.75.10648	7	Au	M4	P1
TAA.311.75.10650	8	Au	M4	P1
TAA.311.75.10661	9	Au	M4	P1
TAA.311.75.10663	10	Au	M4	P1
TAA.311.75.10667	12	Au	M4	P1
		Resistance (Ω) Widerstand (Ω)		
TAA.179.75.20001	75	Ni	-	-

Model / Modell

Straight plug with resistance (75 Ω) / 0.6 W, screw coupling
Gerader Stecker mit Widerstand (75 Ω) / 0.6 W,
Verbindung mit Schrauben

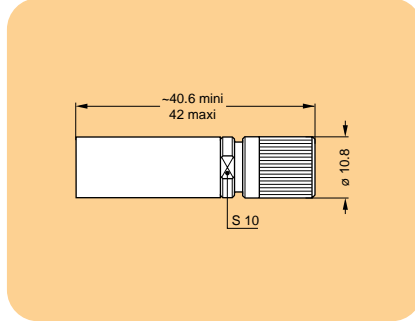

Straight socket with resistance (75 Ω) / 0.6 W
Gerade Apparatedose mit Widerstand (75 Ω) / 0.6 W

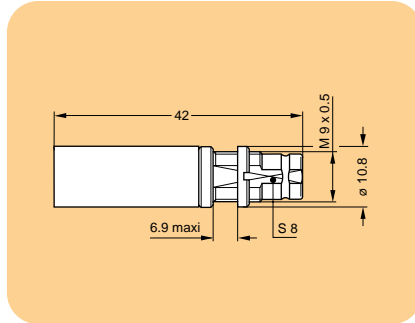
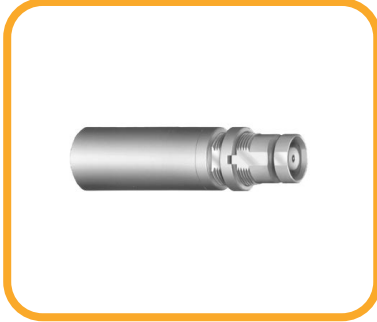

Straight coupler, male-male, Push-Pull self-latching coupling
Gerade Kupplung, Stift-Stift,
Push-Pull selbstverriegelnde Verbindung

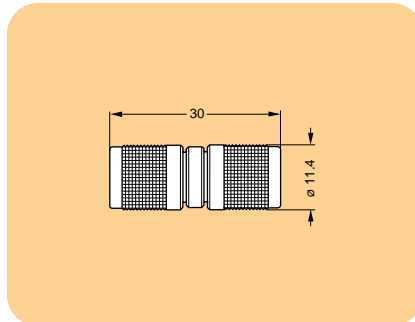
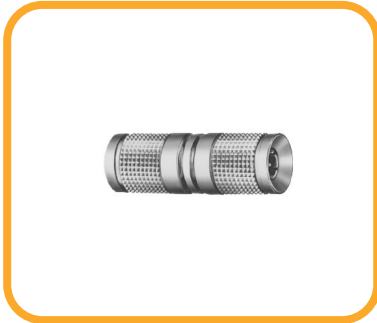

Straight coupler, male-female, Push-Pull self-latching coupling
Gerade Kupplung, Stift-Buchse,
Push-Pull selbstverriegelnde Verbindung

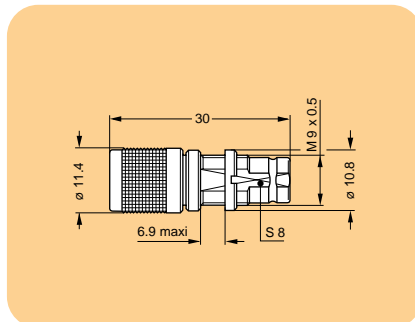
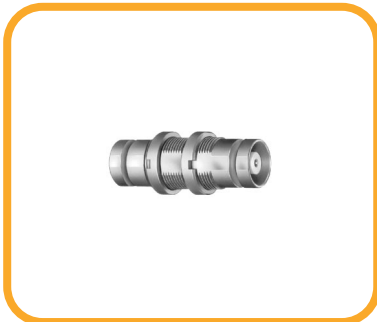

Part Number Bestell-Nummer	Resistance (Ω) Widerstand (Ω)	Housing finish Körperbehandlung	Cable assembly Kabelmontage	Panel hole or printed circuit Bohrung der Frontpl. oder g. S.
TAA.178.75.20001	75	Ni	-	-
TAA.371.75.10001	75	Au	-	P1
TAA.589.75.20200	-	Ni	-	-
TAA.579.75.10500	-	Au	-	-

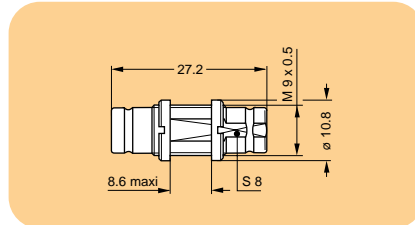
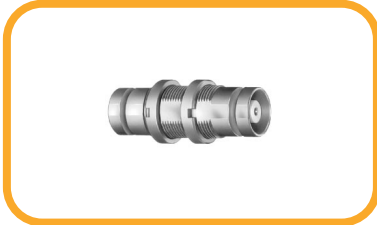
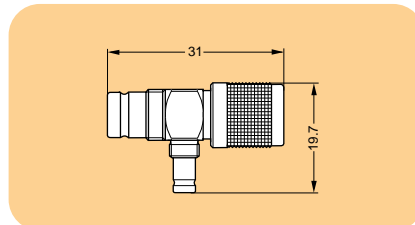
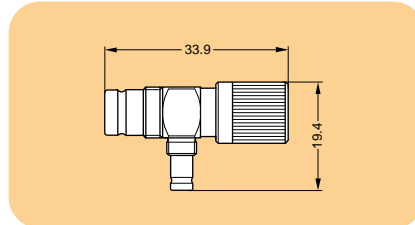
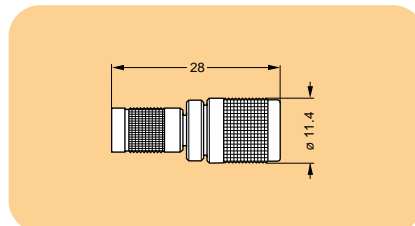
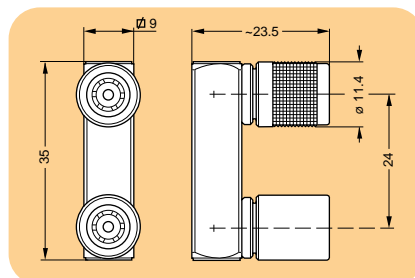
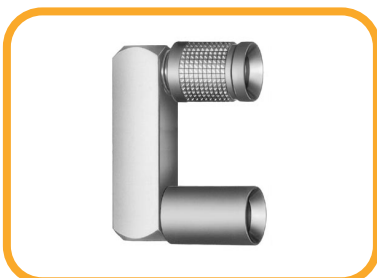
Model / Modell
**Straight coupler, female-female
Gerade Kupplung, Buchse-Buchse**

**«T» adapter, TAA plug and socket, SAA socket,
Push-Pull self-latching coupling
«T» Adapter, TAA Stecker und Apparatedose und SAA Apparatedose,
Push-Pull selbstverriegelnde Verbindung**

**«T» adapter, TAA plug and socket, SAA socket, screw-fixing
«T» Adapter, TAA Stecker und Apparatedose und SAA Apparatedose,
Schraubverbindung**

**Adapter, TAA plug, SAA plug, Push-Pull self-latching coupling
Adapter, TAA Stecker, SAA Apparatedose,
Push-Pull selbstverriegelnde Verbindung**

**Bridge plug, male-male, Push-Pull self-latching coupling
Kupplungstück, Stift-Stift, Push-Pull
selbstverriegelnde Verbindung**

Part Number Bestell-Nummer	Cable group Kabelgruppe	Housing finish Körperbehandlung	Cable assembly Kabelmontage	Panel hole or printed circuit Bohrung der Frontpl. oder g. S.
TAA.515.75.10800	-	Au	-	P1
TAA.599.75.10900	-	Au	-	-
TAA.598.75.10900	-	Au	-	-
TAA.567.75.20200	-	Ni	-	-
TAA.566.75.20024	-	Ni	-	-

M: Cable assembly / Kabelmontage

Straight connectors with cable collet

Gerade Steckverbinder mit Zugentlastung

- 1** Strip cable to dimensions shown in adjacent table.
Kabel gemäss den Angaben der nachstehenden Tabelle abisolieren.

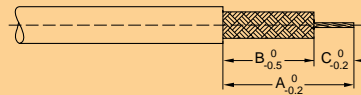

M	Dimensions Dimensionen (mm)		
	A	B	C
M1	15.5	7.5	8.0
M2	13.5	7.5	6.0

- 2** Slide collet nut ① and retaining ring ② over cable. Widen the shield braid. For the 2YCCY cable expand (undo) the first braid, take out the intermediate layers, undo the second braid and reunite the two braids.

Die Spannschraube ① und den Festhaltering ② über das Kabel schieben. Die Abschirmung ausweiten. Für das 2YCCY Kabel, die erste Abschirmung ausweiten, die Zwischenschichten wegnehmen, die zweite Abschirmung ausweiten und die beiden Abschirmungen verbinden.

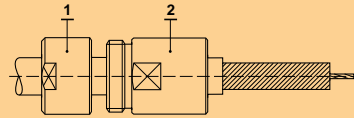

- 3** Slide collet ③ over the cable until the cable jacket butts. Flare the shield braid over the collet collet.

Die Spannzange ③ über das Kabel bis zum Anschlag des Schlauchs schieben. Die Schirmungsdrähte auf die Spannzange aufschürzen.

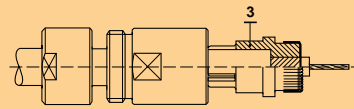

- 4** Slide earthing sleeve ④ over the dielectric and trim excess braid while pushing against the earthing sleeve.

Die Massehülse ④ auf das Dielektrikum schieben und den überstehenden Teil abschneiden.

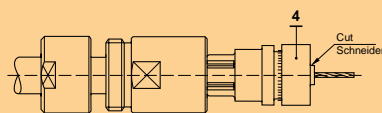

- 5** Slide insulator ⑤ against the earthing sleeve and slide conductor into the contact ⑥, tin solder and take off excess of soldering.

Das Isolationsteil ⑤ gegen die Massehülse schieben und den Leiter in den Kontakt ⑥ einführen. Der Kontakt zinnlöten und auf überstehendes Zinn achten.

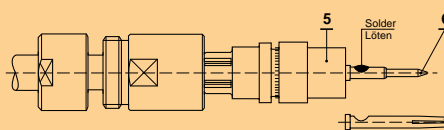

- 6** Slide insulator ⑦ over the contact.
Das Isolierteil ⑦ auf den Kontakt schieben.

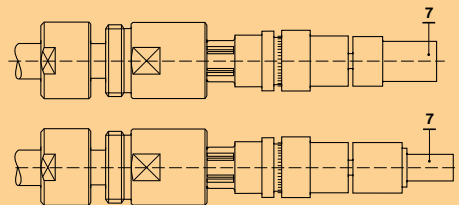

- 7** Slide the pre-assembly into the housing ⑧ and screw retaining ring with two SW10 spanners.

Die montierte Einheit in den Körper ⑧ einführen und den Festhaltering mit zwei SW10 Schlüsseln kontern.

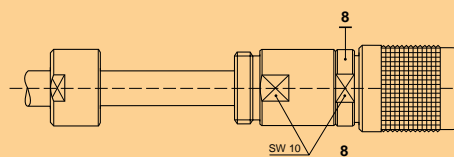

- 8** Screw collet nut over the retaining ring with two SW10 spanners.

Die Spannschraube auf den Festhaltering mit zwei SW10 Schlüsseln schrauben.

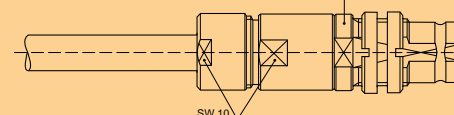

Elbow connectors with cable collet
Winkelstecker mit Zugentlastung

- 4** After operations **1-2-3**, introduce cable into the housing **8**, make sure conductor is correctly located in the contact slot. Screw retaining ring **2** onto housing with SW10 spanner.

Nach der Ausführung der Anleitungen **1-2-3** das Kabel in den Körper **8** einführen, kontrollieren, ob der Leiter richtig in die Kontaktöffnung eingeführt ist. Den Festhaltering **2** auf den Körper mit dem Schlüssel SW10 spannen.

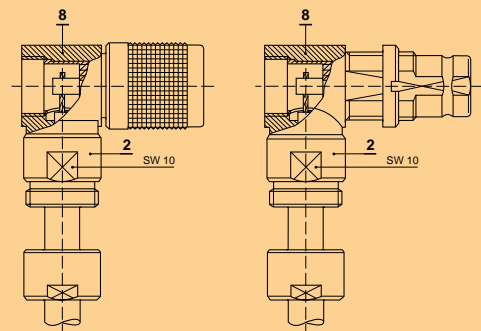

- 5** Screw collet nut **1** to retaining ring with an SW10 spanner. Solder conductor to contact through the access hole.

Die Spanschraube **1** an den Festhaltering mit einem Schlüssel SW10 spannen. Der Kabelleiter mit dem Kontakt durch die Öffnung löten.

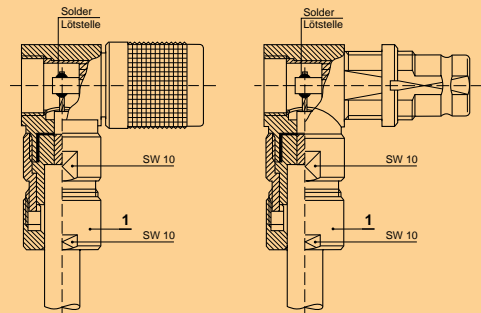

- 6** Introduce insulating washer **9** and close access hole with flat screw **10**.

Die Isolierscheibe **9** einführen und das Loch mit der Schraube **10** schliessen.

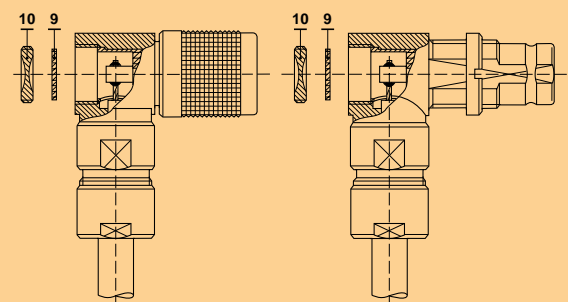
Straight and elbow connectors for crimping
Gerade und Winkel Stecker zum Crimpen

- 1** Strip cable according to dimensions shown in adjacent table. Introduce cable into the crimp ferrule **1**.

Kabel gemäss den Angaben der nachstehenden Tabelle abisolieren. Kabel in die Crimpföhse **1** einführen.

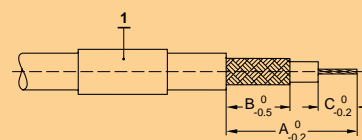

M	Dimensions Dimensionen (mm)		
	A	B	C
M3	12.4	4.4	4.9
M4	13.1	5.8	3.5
M5	15.0	8.0	4.0

- 2** Introduce conductor into the contact **2** and crimp with corresponding tool. Widen the shield braid.

Kabelleiter in den Kontakt **2** einführen. Mit der entsprechenden Zange crimpen. Die Abschirmung ausweiten.

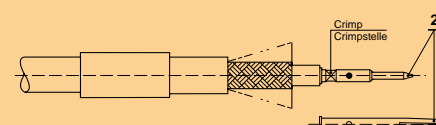

- 3** Introduce cable into connector housing ③ until dielectric butts up against insulator. Slide crimp ferrule over shield braid until it reaches connector housing. Crimp with corresponding tool.

Das Kabel in den Steckerkörper ③ bis zum Anschlag des Dielektrikums gegen das Isolierteil einführen. Die Crimphülse über den Kabelschirm bis zum Anschlag gegen den Steckerkörper schieben. Mit der entsprechenden Zange crimpen.

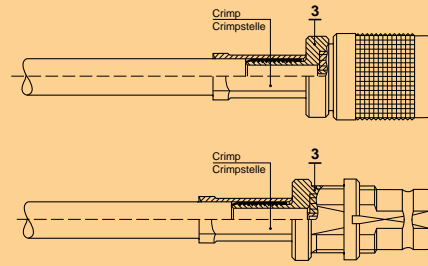

- 4** After operation 1, introduce cable into housing ⑧. Make sure that conductor is correctly located in the contact slot, solder conductor to contact through access hole. Slide crimp ferrule over shield braid until it reaches the housing. Crimp with corresponding tool. Introduce insulating washer ⑨ and close access hole with flat screw ⑩.

Nach der Ausführung der Anleitung 1 das Kabel in den Steckerkörper ⑧ einführen. Kontrollieren, ob der Leiter richtig in die Kontaktöffnung eingeführt ist und durch das Loch den Kabelleiter mit dem Kontakt löten. Die Crimphülse über den Kabelschirm bis zum Anschlag gegen den Steckerkörper schieben. Mit der entsprechenden Zange crimpen. Die Isolierringe ⑨ einführen und das Loch mit der Schraube ⑩ schliessen.

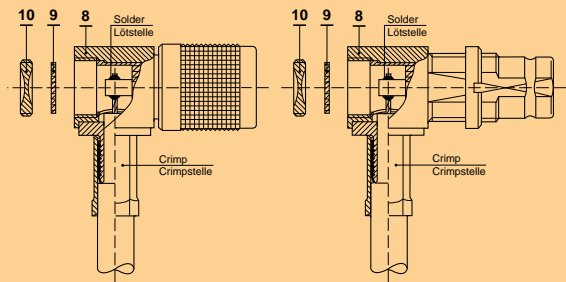

P: Drilling pattern / Bohrungsplan

Panel holes Bohrung der Frontplatte

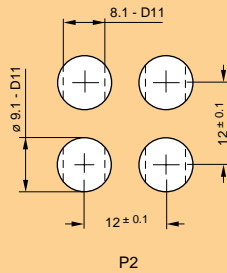

Printed circuit holes Bohrung der gedruckten Schaltung

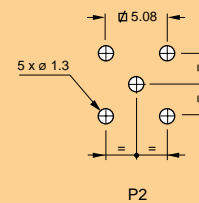

Tool / Werkzeug

Crimping tool Crimpzange

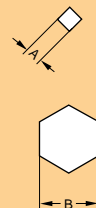
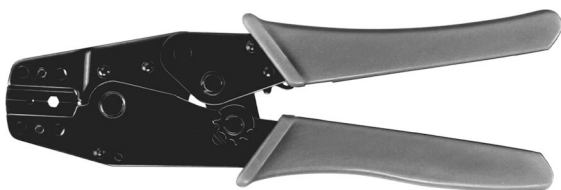

Part Number Bestell-Nummer	Cable group Kabelgruppe	Dimensions Dimensionen (mm)	
		A	B
TAA.950.16380	1-2	1.3	3.4
TAA.950.16440	3	1.3	3.8
TAA.950.16530	4-5-6	1.3	4.7
TAA.950.16630	7-8	1.3	5.5
TAA.950.16750	9-10	1.3	6.4
TAA.950.16470	12	1.3	3.9

Cable assembly / Kabelmontage



COELVER can also provide complete cable-connector assemblies according to customer specifications.

Die Firma COELVER liefert komplett konfektionierte Kabeleinheiten nach Kundenspezifikation.

Recommended cables / Empfohlene Kabel

Part Number/Bestell-Nummer Supplier/Lieferant	Standard Norm		Imp. (Ω)	Conductor Leiter			Dielectric Dielektrikum		Screen Abschirmung		Sheath Außenmantel	
	IEC 96	CCTY 10-01A		Construction Aufbau	Mat. Mat.	∅	Mat. Mat.	∅	Mat. Mat.	∅	Mat. Mat.	∅
RG.59B/U	75-4-1		75	mono/Mono	CuSt	0.60	PE	3.70	Cu	4.50	PVC*	6.10
RG.142B/U	-		50	mono/Mono	CuStAg	0.95	PTFE	2.95	Ag+Ag	4.30	FEP	5.00
RG.174A/U	50-2-1	KX3A	50	7x0.16	CuSt	0.48	PE	1.50	CuSn	2.00	PVC*	2.80
RG.178B/U	50-1-1	KX21A	50	7x0.10	CuStAg	0.30	PTFE	0.84	CuAg	1.30	FEP	1.80
RG.179B/U	75-2-1		75	7x0.10	CuStAg	0.30	PTFE	1.50	CuAg	2.00	FEP	2.50
RG.187A/U	75-2-2		75	7x0.10	CuStAg	0.30	PTFE	1.50	CuAg	2.00	PTFE	2.60
RG.188A/U	50-2-3		50	7x0.18	CuStAg	0.54	PTFE	1.50	CuAg	2.00	PTFE	2.60
RG.196A/U	50-1-2		50	7x0.10	CuStAg	0.30	PTFE	0.84	CuAg	1.30	PTFE	2.10
RG.316/U	50-2-2	KX22A	50	7x0.18	CuStAg	0.54	PTFE	1.50	CuAg	2.00	FEP	2.50
RG.405/U		KS1	50	mono/Mono	CuStAg	0.51	PTFE	1.68	Cu tube	2.20	-	-
EZ 47-50			50	mono/Mono	CuStAg	0.29	PTFE	0.94	Cu tube	1.19	-	-
EZ.86-75			75	mono/Mono	CuStAg	0.29	PTFE	1.70	Cu tube	2.18	-	-
1AC004060001			75	mono/Mono	CuSn	0.25	PTFE	1.19	CuAg	1.58	FEP	2.00
Pope H.130			75	mono/Mono	CuAg	0.25	FEP/PE	1.45	Cu	-	FRNC	2.60
FMC ST.212 (0,4/2,0) R			75	mono/Mono	CuSn	0.40	FEP	2.00	CuSn	2.60	PVC	3.00
Pope H.134			75	mono/Mono	Cu	0.31	PE	1.95	CuAg	-	PVC	3.55
Alcatel thin coax			75	mono/Mono	Cu	0.50	PE	2.30	CuSn	3.10	PVC	3.80
Belden 8218			75	7x0.14	CuSt	0.43	PE	2.54	CuSn	2.90	PVC	3.80
L 910-39			75	mono/Mono	Cu	0.50	PE	2.35	CuSn+CuSn	3.30	P6	3.70
Gore 5YC(ms) C6Y 45/1,9-75 vsws			75	mono/Mono	CuStAg	0.45	PTFE	1.90	CuAg	2.50	PVC	3.30
Siemens 2 YCY (0,4/2,5)			75	mono/Mono	CuSt	0.40	PE	2.50	CuSn	2.80	PVC	3.80
2.5C-2V (JIS C 3501)			75	mono/Mono	Cu	0.40	PE	2.40	Cu	3.00	PVC	4.00
Siemens 2 YCCY (0,4/2,5)			75	mono/Mono	CuSt	0.40	PE	2.50	CuSn	3.70	PVC	4.60
FMC ST.121 (0,5/2,9)			75	mono/Mono	CuSn	0.50	PE	2.90	CuSn	3.70	PVC	4.80
FMC ST. 214 (0,81/3,7) R			75	mono/Mono	CuSn	0.81	FEP	3.70	CuSn+CuSn	5.00	PVC	5.90
Belden 8241			75	mono/Mono	CuSt	0.58	PE	3.71	CuSn+CuSn	4.50	PVC	6.10
Belden YR 23769			75	mono/Mono	Cu	0.60	PE	3.70	CuSn	5.20	PVC	6.30

Abbreviations:

Ag+Ag	Double screen of silver-plated copper
Cu	Bare copper
CuAg	Silver-plated copper
CuSn	Tinned copper
CuSn+CuSn	Double screen of tinned copper
CuSt	Copper-plated steel
CuStAg	Silvered copper plated steel
FEP	Extruded Polytetrafluorethylene
FRNC	Flame retardant non corrosive
PE	Polyethylene
PTFE	Wrapped or extruded Polytetrafluorethylene
PVC	Polyvinylchloride
PVC*	Polyvinylchloride (Qual. IIa MIL-C-17)
P6	Polyamide

Abkürzungen:

Ag+Ag	Doppelschirmung aus versilbertes Kupfer
Cu	Kupfer, blank
CuAg	Kupfer, versilbert
CuSn	Kupfer, verzinkt
CuSn+CuSn	Doppelschirmung aus verzinnertes Kupfer
CuSt	Stahl, verkupfert,
CuStAg	Stahl, verkupfert, versilbert
FEP	Polytetrafluorethylen extrudiert
FRNC	Schwer entflammbar
PE	Polyethylen
PTFE	Polytetrafluorethylen, bandiert oder extrudiert
PVC	Polyvinylchlorid
PVC*	Polyvinylchlorid (Qual. IIa MIL-C-17)
P6	Polyamide

